



300 HUEY LENARD LOOP | WEST MONROE | LA 71292
 OFFICE: 318-397-3000 | FAX: 318-397-3040
 SERVICE & TECH SUPPORT: 800-551-4955
 SUPERLIFT.COM



2019-2020 GM 1500 PICKUP 4WD 6 Inch Lift Kit INSTALLATION INSTRUCTIONS

Engineered for 4WD Models ONLY.

Fits: 2019-2020 Chevrolet Silverado 1500 4WD
 2019-2020 GMC Sierra 1500 4WD

- ⚠️ **NOTE:** Does NOT Fit 2019 "Classic" Models (2018 Body Style)
- Does NOT Fit Chevy Silverado Trail Boss Models
- Does NOT Fit GMC Sierra AT4 Package Equipped Models
- Does NOT Fit Models with Adaptive Ride Control



⚠️ CAUTION: MAKE SURE YOU HAVE THE CORRECT LIFT FOR YOUR VEHICLE:
 Double check the Year, Make, Model, Lift Height and KIT Part Numbers.

⚠️ NOTE: Prior to beginning the installation, OPEN the Boxes and CHECK the Included Components Compared to the Parts Breakdown. Check all parts and hardware in the box with the parts list below. Be sure you have all needed parts and know where they install.

IF you find a packaging error, contact SUPERLIFT directly. Do not contact the dealer where the system was originally purchased. You will need the control number from each box when calling; this number is located at the bottom of the part number label and to the right of the bar code.

- ① Rear Fab Blocks
- ② 7/16" Ubolts, Flange Nuts & Block Shims
- ③ SUPERLIFT or BILSTEIN Shocks, Rear
- ④ Brake Line Bracket, Rear
- ⑤ 9/16" Ubolts, High Nuts & Washers
- ⑥ Crossmember, Rear
- ⑦ Differential Drop Brackets, (1) DR & (2) PA Side
- ⑧ Struts Spacers, DR & PA Side
- ⑨ Sway Bar Drop Brackets, DR & PA Side
- ⑩ Belly Pan
- ⑪ Knuckle, PA Side
- ⑫ Crossmember, Front
- ⑬ Knuckle, DR Side
- ⑭ Eccentric Cam Bolts
- ⑮ Lockout Washers

⚠️ NOTE: K182B Shown with BILSTEIN Rear Shocks. K182 Includes SUPERLIFT Shocks.

How to Read the Kit Breakdown Charts:

The 'K KIT BREAKDOWN' lists the Part Numbers, Quantities & Part Description of the Boxes that are included in the K KIT. The 'KIT BREAKDOWN' lists Part Numbers, Quantities & Part Description of the Individual Components & Hardware Bags that are included in Each Box. The 'HARDWARE BREAKDOWN' lists the Part Numbers, Quantities & Part Description of the Individual Components.

K KIT BREAKDOWN					
6" Lift Kit with SUPERLIFT Shocks			6" Lift Kit with BILSTEIN Shocks		
Kit Part Number	K182	Part Description	Kit Part Number	K182B	Part Description
3590	1	Kit Box, Knuckle, Driver Side	3590	1	Kit Box, Knuckle, Driver Side
3591	1	Kit Box, Knuckle, Passenger Side	3591	1	Kit Box, Knuckle, Passenger Side
3592	1	Kit Box, Sway Bar Drops, Diff. Drops & Strut Spacers	3592	1	Kit Box, Sway Bar Drops, Diff. Drops & Strut Spacers
3593	1	Kit Box, Front & Rear Crossmembers & Belly Pan	3593	1	Kit Box, Front & Rear Crossmembers & Belly Pan
3594	1	Kit Box, Rear Block Kit	3594	1	Kit Box, Rear Block Kit
84022	1	Kit Box, SUPERLIFT Rear Shocks	84023	1	Kit Box, BILSTEIN Rear Shocks

KIT BOX BREAKDOWN					
3590			3594		
Part Number	Qty.	Part Description	Part Number	Qty.	Part Description
66-01-3590	1	Knuckle, Driver Side	55-05-201	2	Block, Rear (6")
77-3590	1	Hardware Bag	55-15-3590	1	Brake Line Bracket, Rear
3591			3594		
66-01-3591	1	Knuckle, Passenger Side	55-03-200	2	10 GA Spacer, Block Shim
77-3590	1	Hardware Bag	55-07-200	2	7 GA Spacer, Block Shim
3592			84022		
55-03-3590	1	Differential Drop, Driver Side	10482	4	9/16" x 2-1/2" x 11-1/2" Ubolt, Square
55-04-3590	1	Differential Drop, Passenger Side	77-1509	1	Hardware Bag
55-10-3590	1	Differential Support Drop, Passenger Side	77-1507	1	Hardware Bag
55-11-3590	1	Sway Bar Drop, Driver Side	77-3594	1	Hardware Bag
55-12-3590	1	Sway Bar Drop, Passenger Side	84023		
55-07-3590	2	Strut Spacer (6")	Part Number	Qty.	Part Description
77-3592	1	Hardware Bag	01-85150 (650341)	2	SUPERLIFT Rear Shocks
77-3592A	1	Hardware Bag	77-80033	1	Shock Hardware Bag
3593			84023		
Part Number	Qty.	Part Description	Part Number	Qty.	Part Description
55-05-3590	1	Crossmember, Front	33-185569	2	BILSTEIN Rear Shocks
55-06-3590	1	Crossmember, Rear	77-80033	1	Shock Hardware Bag
55-09-3590	1	Belly Pan			
77-3593	1	Hardware Bag			

HARDWARE BREAKDOWN					
77-3590			77-3593		
Part Number	Qty.	Part Description	Part Number	Qty.	Part Description
F470L	1	F470L, Thread Locker	916X4C8CS	1	9/16" X 4" Bolt, Coarse Grade 8
38ADC	3	3/8" Adel Clamp	916SW	2	9/16" Flat Washer, SAE
77-3592			77-1507		
10MFN	6	10mm Flange Nut 7.9M Height, Plated	916C5NN	1	9/16" Nyloc Nut, Coarse Grade 5
10MPN	6	10mm Push Nut	55-21-9940	8	Cam Washer, 18mm FD F150 04-08
10MX1.5X35CB	6	10mm x 1.5 x 35mm, Carriage Bolt	55-16-3590	8	Lockout Washer - 2019+ GM
12C5NN	2	1/2" Nyloc Nut, Coarse Grade 5	55-13-3590	4	Cam Bolt - 2019+ GM
12SW	4	1/2" Flat Washer, SAE	38X1C5CB	5	3/8" X 1" Bolt, Carriage Bolt, Coarse G5
12X112C8CS	2	1/2" X 1-1/2" Bolt, Coarse Grade 8	38C5FN	5	3/8 Grade 5 Coarse Flange Nut
38C5NN	4	3/8" Nyloc Nut, Coarse Grade 5	18MX2.5X130CS	4	18mm X 2.5 X 130mm Bolt, 10.9 Grade
38X114C8CS	4	3/8" X 1-1/4" Bolt, Coarse Grade 8	18MNN	8	18mm Nyloc Nut, 2.5 pitch
38SW	8	3/8" Flat Washer, SAE	77-1509		
58C5NN	1	5/8" Nyloc Nut, Coarse	Part Number	Qty.	Part Description
58SW	2	5/8" Flat Washer, SAE	716X314X412UB	4	7/16" x 3-1/4" x 4-1/2" Ubold, Square
58X5C8CS	1	5/8" X 5" Bolt, Coarse Grade 8	716F85FN	8	7/16" Nut, Nyloc Coarse Thread
916C5NN	2	9/16" Nyloc Nut, Coarse Grade 5	77-1509		
916SW	4	9/16" Flat Washer, SAE	Part Number	Qty.	Part Description
916X4C8CS	2	9/16" X 4" Bolt, Coarse Grade 8	1511-B09	8	9/16" High Nut, Fine Thread
			1509	8	9/16" Ubold Washer
77-3592A			77-3594		
Part Number	Qty.	Part Description	Part Number	Qty.	Part Description
.188 x .375 Tubing	4	.188 x .375 Vacuum Line Tubing, Per Inch	516X1C8CS	2	5/16" x 1" Bolt, Coarse Thread
17-9690	1	3/16" Vacuum Connector	516C5NN	2	5/16" Nut, Nyloc Coarse Thread
F470L	1	Thread Locker #27105	516SW	4	5/16" Washer, SAE
			77-80033		
			Part Number	Qty.	Part Description
			01-60418	4	Shock Eye Bushing
			34SW	4	3/4" SAE washer
			39-3480	4	Shock Eye Sleeve

Step	Part Number	Qty. Per Kit	Description	New Attaching Hardware	Qty. Per Bracket	Hardware Bag Number	
17	55-03-3590	1	Differential Drop, Driver Side	9/16" x 4" Bolt, Course Thread	1	77-3591	
				9/16" Nut, Nyloc Coarse Thread	1		
				9/16" Washer, SAE	2		
17	55-04-3590	1	Differential Drop, Passenger Side	9/16" x 4" Bolt, Coarse Thread	1	77-3591	
17	55-10-3590	1	Differential Support Drop, Passenger Side	9/16" Nut, Nyloc Coarse Thread	1		
				9/16" Washer, SAE	2		
				5/8" x 5" Bolt, Coarse Thread	1		
				5/8" Nut, Nyloc Coarse Thread	1		
				5/8" Washer, SAE	2		
				1/2" x 1-1/2" Bolt, Coarse Thread	2		
				1/2" Nut, Nyloc Coarse Thread	2		
				1/2" Washer, SAE	4		
17				3/16" x 4" Vacuum Hose	1	77-3592A	
				3/16" Hose Adapter	1		
				F470L, Thread Locker	1		
18	55-06-3590	1	Crossmember, Rear	18mm x 130mm Bolt, 2.5 Pitch	2	77-3593	
				55-16-3590 - Lockout Washer	4		
				18mm Nut, Nyloc 2.5 Pitch	2		
				9/16" x 4" Bolt, Coarse Thread	1		
				9/16" Washer, SAE	2		
				9/16" Nut, Nyloc Coarse Thread	1		
				55-13-3590 - Cam Bolt	2		
				55-21-9940 - Cam Washer	4		
19	55-05-3590	1	Crossmember, Front	18mm x 130mm Bolt, 2.5 Pitch	2	77-3593	
				55-16-3590 - Lockout Washer	4		
				18mm Nut, Nyloc 2.5 Pitch	2		
				55-13-3590 - Cam Bolt	2		
				55-21-9940 - Cam Washer	4		
25	55-07-3590	2	Strut Spacer (6")	10mm x 35mm Bolt, Carriage 1.5 Pitch	3	77-3591	
				10mm Nut, Flange	3		
				10mm Nut, Push	3		
27	55-11-3590	1	Sway Bar Drop, Driver Side	3/8" x 1-1/4" Bolt, Coarse Thread	2	77-3591	
				3/8" Nut, Nyloc Coarse Thread	2		
				3/8" Washer, SAE	4		
27	55-12-3590	1	Sway Bar Drop, Passenger Side	3/8" x 1-1/4" Bolt, Coarse Thread	2	77-3591	
				3/8" Nut, Nyloc Coarse Thread	2		
				3/8" Washer, SAE	4		
28-29	66-01-3590	1	Knuckle, Driver Side	F470L, Thread Locker	1	77-3590	
				3/8" Adel Clamp	3		
28-29	66-02-3590	1	Knuckle, Passenger Side	F470L, Thread Locker	1	77-3590	
				3/8" Adel Clamp	3		
34	55-09-3590	1	Belly Pan	3/8" x 1" Bolt, Carriage Coarse Thread	5	77-3592	
				3/8" Nut, Flange	5		
40	55-15-3590	1	Brake Line Bracket, Rear	5/16" x 1" Bolt, Coarse Thread	2	77-3594	
				5/16" Nut, Nyloc Coarse Thread	2		
				5/16" Washer, SAE	4		
43	55-05-201	2	Block, Rear (6")	10482 - 9/16" x 2-1/2" x 11-1/2" Ubolt, Square	2	77-1509	
				9/16" High Nut, Fine Thread	4		
				9/16" Ubolt Washer	4		
				7/16" x 3-1/4" x 4-1/2" Ubolt, Square Fine Thread	2		77-1507
				7/16" Nut, Flange Fine Thread	4		
				55-03-200 10 GA Spacer, Block Shim	1		
55-07-200 7 GA Spacer, Block Shim	1						
44	01-85150 (650341)	2	SUPERLIFT Shock, Rear	01-60418, Hourglass Bushing	2	77-80033	
				39-3480, 0.75" OD x 0.5630" ID x 1.68" L, Sleeve	2		
				3/4" Washer, SAE	2		
OR							
44	BE5-6249-H5	2	BILSTEIN 5100 SERIES Shock, Rear	01-60418, Hourglass Bushing	2	77-80033	
				39-3480, 0.75" OD x 0.5630" ID x 1.68" L, Sleeve	2		
				3/4" Washer, SAE	2		

THANK YOU FOR CHOOSING SUPERLIFT FOR ALL YOUR SUSPENSION NEEDS!!**INTRODUCTION BEFORE INSTALLATION...**

Installation requires a professional mechanic. In addition to these instructions, professional knowledge of disassembly / reassembly procedures and post installation checks must be known.

PRIOR to beginning, inspect the vehicles steering, driveline, and brake systems, paying close attention to the suspension link arms and bushings, sway bars and bushings, tie rod ends, pitman arm, idler arm, ball joints and wheel bearings. Also check the steering sector-to-frame and all suspension-to-frame attaching points for stress cracks. The overall vehicle must be in excellent working condition; repair or replace all worn parts.

Read instructions several times before starting. Read each step completely as you go.

Be sure you have all needed parts and know where they install.

⚠ NOTES:

- Do NOT install this suspension system in conjunction with any other type of aftermarket or fabricated components to gain additional suspension height.
- Do not fabricate any components to gain additional suspension height.
- Prior to drilling or cutting, check behind the surface being worked on for any wires, lines, or hoses that could be damaged. Prep all cutting surfaces by removing all debris and frame coatings.
- After drilling, file smooth any burrs and sharp edges.
- Prior to operating a torch or saw, protect any heat-sensitive components located in the immediate area by covering them with a water-saturated cloth. Most undercoating are flammable, but can be extinguished using a water-filled spray bottle. Have an ABC rated fire extinguisher on hand.
- Paint or undercoat all exposed metal surfaces.
- Prior to attaching components, be sure all mating surfaces are free of grit, grime, grease, undercoating, etc.
- Front end alignment is necessary.
- Tool and Wrench/Socket size is given in brackets [] after each appropriate step.
- A foot-pound torque reading is given in parenthesis () after each appropriate fastener.
- Always wear safety glasses when using power tools.
- A factory service manual should be on hand for reference.

BEFORE YOU DRIVE...

Check all fasteners for proper torque. Check to ensure for adequate clearance between all rotating, mobile, fixed, and heated members. Verify clearance between exhaust and brake lines, fuel lines, fuel tank, floor boards and wiring harness. Check steering components for clearance.

Test and inspect brake system. Perform steering sweep to ensure front brake hoses have adequate slack and do not contact any rotating, mobile or heated members. Inspect rear brake hoses at full extension for adequate slack. Failure to perform hose check/replacement may result in component failure.

Perform head light check and adjustment.

⚠ WARNING: It is ultimately the buyer's responsibility to have all bolts / nuts checked for tightness after the first 100 miles and then every 1000 miles. The steering, suspension and driveline systems, plus wheel alignment should be inspected by a qualified professional mechanic at least every 3000 miles.

TIRES & WHEELS...

Larger rim and tire combinations may increase leverage on suspension, steering, and related components. When selecting combinations larger than OE, consider the additional stress you could be inducing on the OE and related components.

⚠ NOTE: Stock 18" & 20" Wheels Will NOT Fit back on the vehicle once this suspension system is installed.

⚠️ WARNING: ANY larger or wider tire & wheel combination other than listed Will Require Vehicle Trimming.

🚫 CAUTION: The 2019 and Newer Chevy Silverado & GMC Sierra have a Larger Brake Caliper that extends or sticks out past the mounting surface of the wheel. Your choice of aftermarket wheels must be specifically for the 2019 & Newer GM models. Backspacing is still crucial, but the wheel's design must state it fits these newer brake caliper models.

⚠️ NOTE: ALL Tire & Wheel Combinations Should Be Test Fit Prior to Installation. * Some Minor Trimming Maybe Required. Some minor trimming will be required with certain wheel/tire combinations. This is normal with most aftermarket tire/wheel fitments on GM trucks. Trimming will normally include the bottom edge of the inner fender shrouds and/or lower corner of front bumper valance. As a rule of thumb, deeper backspacing and shorter/narrower tires will reduce/eliminate trimming required.

IMPORTANT DISCLAIMER: The provided tire/wheel fitments are approximate. Actual dimensions of a given tire size can vary considerably from one brand to another. Manufacturers' wheel offset and backspacing measurement points are not always consistent. Backspacing greatly impacts tire-to-fender clearance when turning. Wheel width and backspacing influence whether the tires protrude past the fenders, and to what extent. Considering these important factors, we recommend that you fit-check your tire/wheel selection prior to purchasing. The provided tire/wheel fitments are approximate.

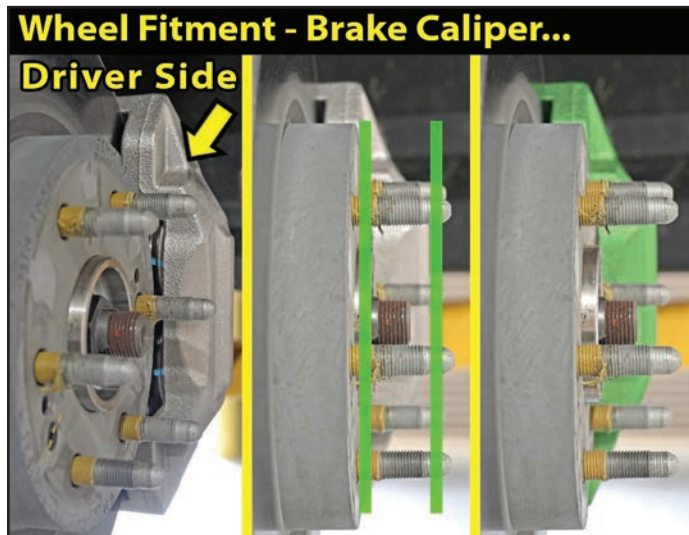

TOOLS & TECH...

The chart is a listing of the main tools need to install this lift kit system.

We have also included a **Tech Tip** noted by this icon

🔧 TECH TIP to help if we have found a quicker or easier way to accomplish a task in the steps.

TIRE SIZE SPECIFICATIONS			
Tire Size	Wheel	Backspacing (INCH)	Offset (MM)
35x12.50R20	20x9	4.5	-12mm
315/60R20	20x9	4.5	-12mm
35x12.50R20	20x10		-24mm
315/60R20	20x10		-24mm
35x12.50R22	22x9	4.5	-12mm
295/50R22	22x9	4.5	-12mm
35x12.50R22	22x10		-24mm
325/50R22	22x10		-24mm

Tools			
Miscellaneous Tools		Wrench / Socket Sizes	
		Standard	Metric
Floor Jacks	Jack Stands		
Ball-Peen Hammer	Chisel	5/16"	10mm
Adjustable Pliers	Vice Grips	7/16"	13mm
Torque Wrench	Pry Bar	1/2"	15mm
Assorted Length Socket Extensions		9/16"	18mm
Swivel Socket		5/8"	19mm
Plastic Fastener Removal Tool		11/16"	21mm
Mechanic Pick		3/4"	22mm
5/32" & 3/16" Allen Wrench		13/16"	27mm
T30 & T15 Torx Bit & Driver		7/8"	36mm

Torque Specifications					
STANDARD			METRIC		
Size	Grade 5	Grade 8	Size	Grade 8.8	Grade 10.9
5/16"	15 ft/lbs.	20 ft/lbs.	6mm	5 ft/lbs.	9 ft/lbs.
3/8"	30 ft/lbs.	35 ft/lbs.	8mm	18 ft/lbs.	23 ft/lbs.
7/16"	45 ft/lbs.	60 ft/lbs.	10mm	32 ft/lbs.	45 ft/lbs.
1/2"	65 ft/lbs.	90 ft/lbs.	12mm	55 ft/lbs.	75 ft/lbs.
9/16"	95 ft/lbs.	130 ft/lbs.	14mm	85 ft/lbs.	12 ft/lbs.
5/8"	135 ft/lbs.	175 ft/lbs.	16mm	130 ft/lbs.	165 ft/lbs.
3/4"	185 ft/lbs.	280 ft/lbs.	18mm	170 ft/lbs.	240 ft/lbs.

NOTE: Use the check-off box found at each step to help you keep your place. Two denotes that one check-off box is for the Driver Side (Left) and one is for the Passenger Side (Right). Unless otherwise noted, always start with the Driver Side.

FRONT DISASSEMBLY

NOTE: Save all factory components and hardware for reuse, unless noted.

1. PREPARE VEHICLE...

WARNING: [Illustration 1] To properly support the 2019+ Silverado 1500 & Sierra 1500 trucks, wider lift pad adapters are required because the frame is wider than the previous trucks in the area where the front hoist arm lift pads need to be positioned.

Chock rear tires and place transmission in neutral. Raise front of vehicle with a jack and secure a jack stand beneath each frame rail. Ease the frame down onto the stands and place transmission in park.

Raise the hood and disconnect the battery. [10mm]

Remove front tires and wheels. [Lug Nuts 22mm]

2. REMOVE FACTORY BELLY PAN & SPLASH GUARD...

[Illustration 2] If equipped, remove the four (4) bolts mounting the factory belly pan to the crossmembers. [13mm] Remove the two (2) bolts mounting the front plastic splash guard to the frame. [13mm] The factory belly pan & splash guard will not be reused.

[Illustration 1]



[Illustration 2]

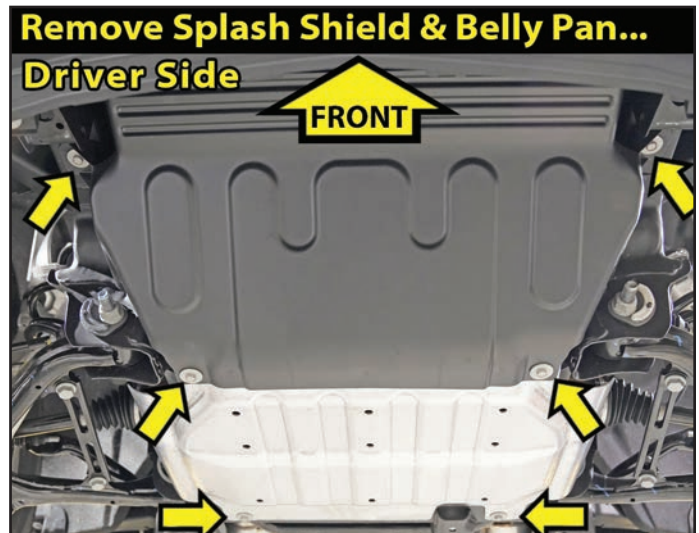

3. UNPLUG RACK & PINION AND DIFFERENTIAL ACTUATOR...

CAUTION: These plugs are "locked" with plastic clips that must be moved to an "unlocked" position before removal. The wire loom is connected to the differential in several places, make sure these are unclipped before removal of differential.

[Illustration 3] **WARNING:** The Battery MUST BE Disconnected: Carefully unplug the bottom three (3) plugs from the rack and pinion. Unplug the differential actuator connector. Follow the wire loom up from the differential actuator and unclip the wire loom clips from the frame. [plastic fastener removal tool]

[Illustration 3]



NOTE: Perform Steps 4-10 One Side At A Time. Start on the Driver Side & Complete Steps 4-10. THEN Go to the Passenger Side & Complete Steps 4-10.

4. DISCONNECT SWAY BAR LINKS...

☐☐ [Illustration 4] On each side, disconnect the sway bar link from the Lower Control Arm (LCA). [18mm]

5. STEERING TIE ROD END...

☐☐ [Illustration 5] Remove the nut from the tie rod end [21mm] Reinstall the nut a couple of turns by hand. Use a Tie Rod Puller to separate the tie rod from the knuckle. Remove the tie rod nut and save for re-install. **TECH TIP** If you do not have a puller, you can use the method of striking the tie rod boss of the knuckle near the ball joint end to dislodge from the knuckle. Do Not strike the tie rod end, brake rotor or dust shield: Strike the knuckle portion only.

[Illustration 4]



[Illustration 5]

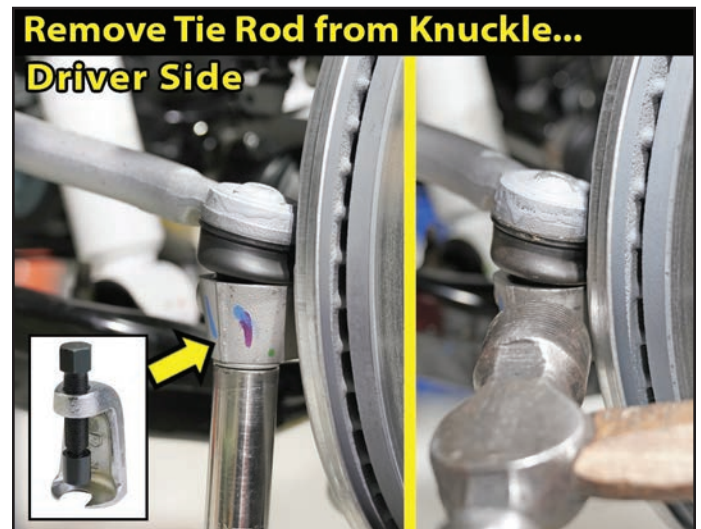

6. REMOVE ABS & BRAKE LINE BRACKETS FROM KNUCKLE...

- [Illustration 6-A] Above the tie rod boss on the knuckle, remove the ABS line from the knuckle. [10mm]
- [Illustration 6-B] Follow the ABS line up the front of the knuckle and remove the ABS line bracket from the knuckle. [10mm]
- [Illustration 6-C] On the rear side of the knuckle, unplug the brake pad wear sensor from the brake caliper. Follow the line up and remove the brake pad wear sensor bracket from the knuckle. [10mm]
- [Illustration 6-D] Unbolt the brake line bracket from the rear side of the knuckle. [10mm]
- [Illustration 6-E] Unbolt the ABS/brake pad wear sensor bracket from the inward side of the knuckle. [10mm]

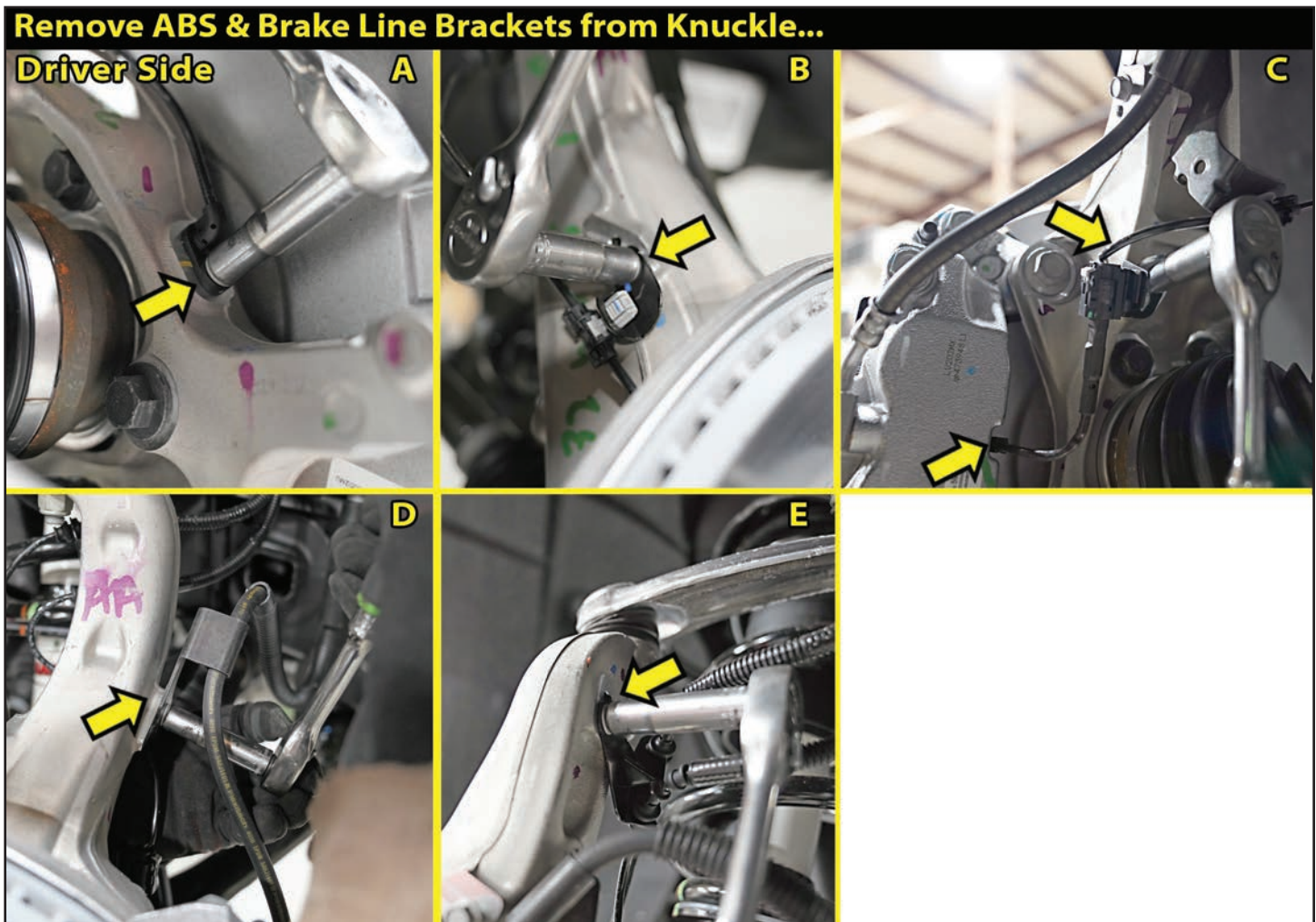
[Illustration 6]**7. REMOVE CV AXLE SHAFT NUT...**

- [Illustration 7] Remove the nut and washer securing the axle shaft to the hub assembly. [36mm]

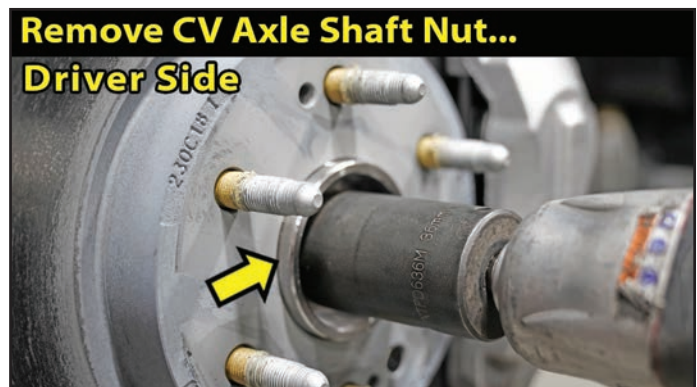
[Illustration 7]

8. DISCONNECT BRAKE CALIPER & REMOVE BRAKE ROTOR...

☐☐ [Illustration 8] Unbolt the two (2) bolts that hold the brake caliper to the knuckle. Remove the brake caliper from the rotor. Secure the caliper away from the work area. **⚠ NOTE:** Do not let calipers hang from brake lines. [18mm]

☐☐ [Illustration 8] Remove the torx bolt retaining the rotor to the hub assembly, remove the brake rotor, and set it aside. [T30]

Illustration 8]

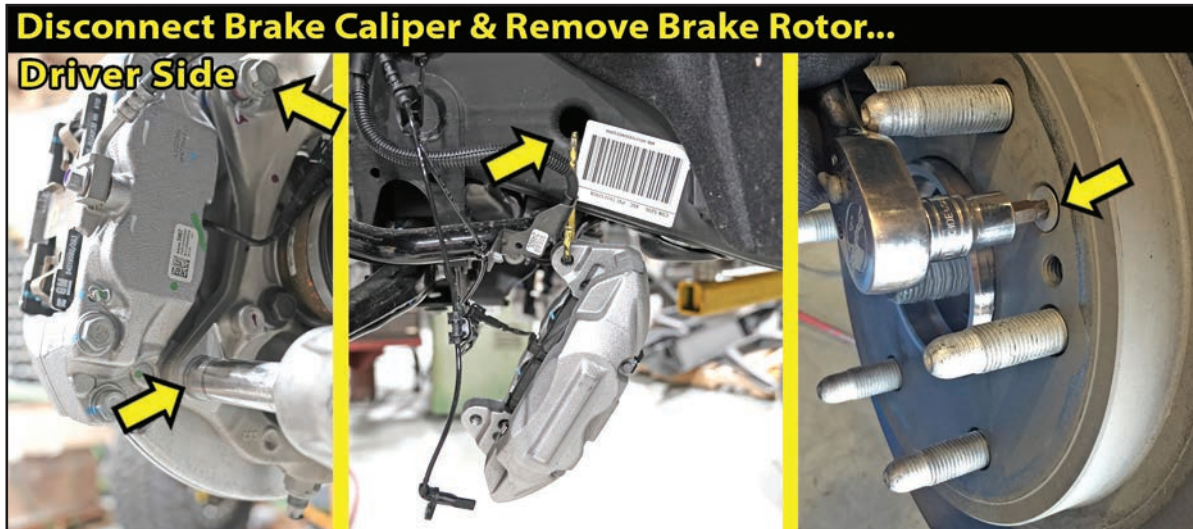

9. DISCONNECT BALL JOINT & REMOVE KNUCKLE ASSEMBLY...

Using a jack, slightly lift the Lower Control Arm (LCA) & knuckle assembly to prevent the arms from being at full droop.

☐☐ [Illustrations 9-A] Remove the nut from the Upper Ball Joint (UBJ) [21mm], then using the appropriate puller tool, disconnect the ball joints from the knuckle. **🔧 TECH TIP** [Illustrations 9-B] If you do not have a puller tool, you can use a hammer by very carefully striking the ball joint boss' of the knuckle; do not strike the ball joints.

Lower the jack to allow the removal of the knuckle assembly from the UBJ, but keep the jack in place. Secure the knuckle forward to allow access to the Lower Ball Joint (LBJ) & lower strut mount.

☐☐ [Illustrations 9-C] Remove the nut from the Lower Ball Joint (LBJ) [24mm] If the LBJ does not come loose easily, use a hammer to strike the ball joint boss' of the knuckle; do not strike the ball joints. [Illustrations 9-D]

⚠ WARNING: Be careful. Do NOT let the knuckle fall to the side abruptly. It could cause damage to the ABS wires or brake lines. Do NOT let the CV axle shaft dislodge from the CV cup or 'pull out' at the differential.

☐☐ **🔧 TECH TIP** [Illustrations 9-E] It may be necessary to use a pry bar to lower the UCA to be able to disconnect the UBJ.

☐☐ [Illustrations 9-F] Remove knuckle from vehicle. **⚠ WARNING:** Be careful. Do NOT let the CV axle shaft dislodge from the CV cup or 'pull out' at the differential.

🔧 TECH TIP When you remove a factory nut or bolt, like the upper and lower ball joint nuts, put it back into the factory spot for safe keeping. You will not have to look or sort through removed hardware to find the proper nut. Same with sway bar bushings & nut, etc.

[Illustration 9]

Disconnect Ball Joints & Remove Knuckle Assembly...

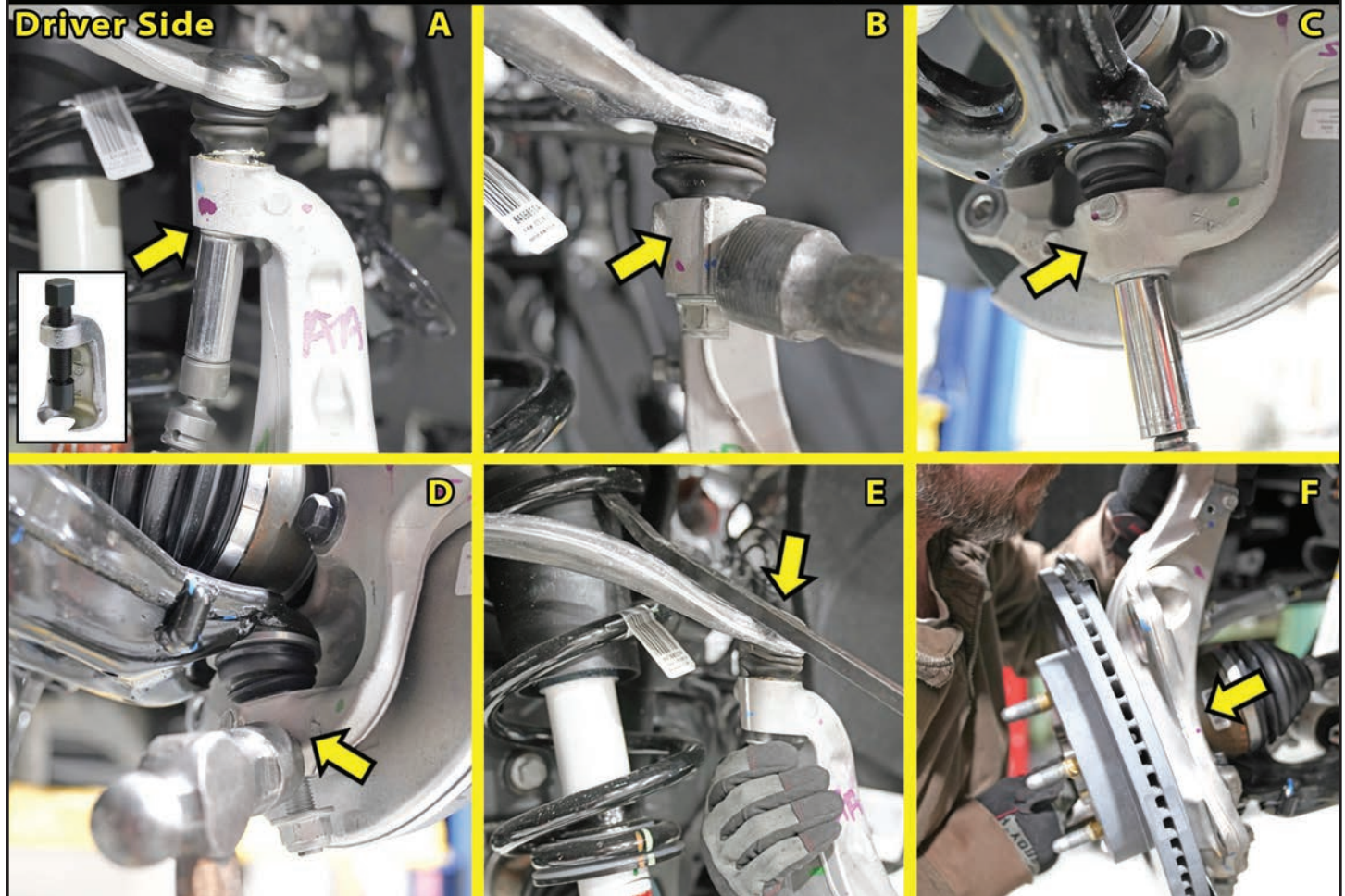

10. REMOVE STRUT...

⚠ NOTE: Before you completely remove the strut, 'Mark' the Alignment of the upper strut mount, upper isolator & spring seat. Also Mark 'DR.' & 'PA.' Side.

- [Illustration 10-A] Remove the two bolts securing the strut to the lower control arm; allow the lower control arm to hang, while you move to the upper strut mount. [15mm]
- [Illustration 10-B] Unclip the wire clips located on the top of the studs. [plastic fastener removal tool]
- [Illustration 10-C] Remove three nuts securing the strut to the frame then remove the strut. [18mm]
- Remove the strut from the vehicle.

Repeat Steps 4 through 10 on the Passenger Side.

[Illustration 10]

Remove Strut...



11. DISCONNECT & REMOVE SWAY BAR ASSEMBLY...

[Illustration 11] Remove the two (2) nuts per side from the mount securing the sway bar to the frame. Retain factory hardware. [10mm]
Remove the sway bar bushing mount and sway bar.

⚠ NOTE: Note the orientation of the sway bar for reference during reassembly.

Mark DR & PA.

12. DISCONNECT & REMOVE LOWER CONTROL ARM...

[Illustration 12] Unbolt the Lower Control Arm (LCA) front mount from the front crossmember. [bolt: 27mm | nut: 27mm]

Unbolt the LCA rear mount from the rear crossmember. [bolt: 27mm | nut: 27mm] Remove LCA.

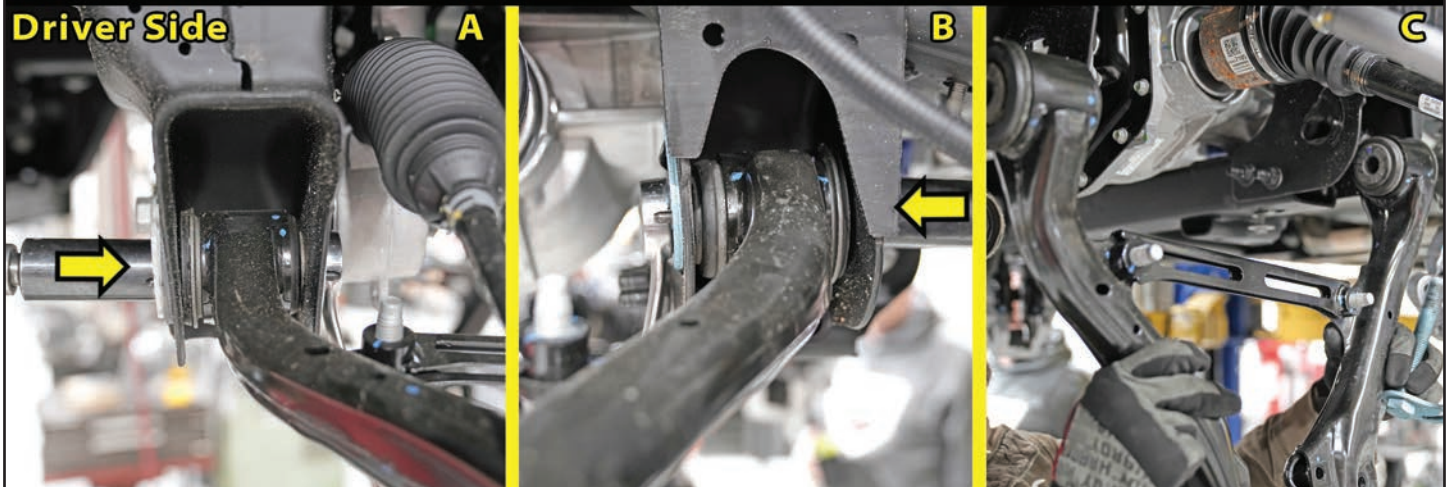
[Illustration 12]**Disconnect & Remove Lower Control Arm (LCA)...****13. MARK & DISCONNECT FRONT DRIVESHAFT...**

[Illustration 13] Mark the orientation of the driveshaft for reference during reassembly. Remove the six (6) bolts with their securing plates from the driveshaft. [10mm] **⚠ NOTE:** Do Not allow the driveshaft to hang freely from the rear joint: this could damage the boot.

Secure the driveshaft up and out of the way. Retain factory hardware.

[Illustration 13]**Mark & Disconnect Front Driveshaft... Driver Side**

14. DISCONNECT REAR DIFFERENTIAL MOUNT & REMOVE REAR CROSSMEMBER...

- Support the differential housing with a jack.
- [Illustration 14-A] Remove the rear differential mounting bolt from the rear crossmember. [21 mm] Retain factory hardware.
- [Illustration 14-B] Remove the four (4) bolts securing the rear crossmember from the frame. Two (2) Per Side. [bolt: 15mm | nut: 18mm] Discard crossmember.

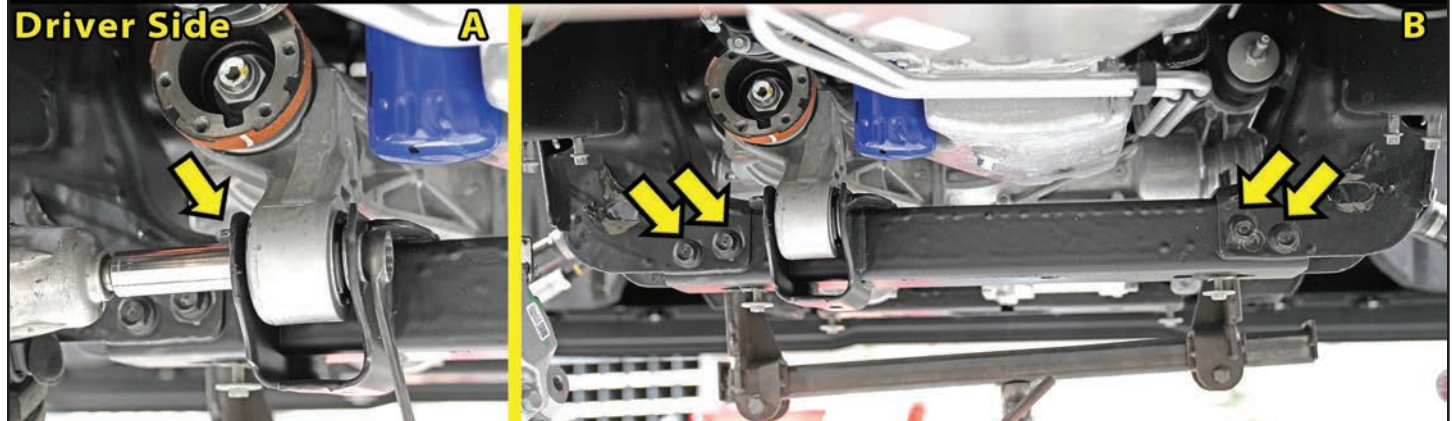
[Illustration 14]**Disconnect Rear Diff Mount & Remove Rear Crossmember...****15. DISCONNECT REAR DIFFERENTIAL MOUNT & REMOVE REAR CROSSMEMBER...**

- [Illustration 15-A] Remove the DR side front differential mounting bolt. [21mm] The nut is welded in place.
- [Illustration 15-B] Remove the PA side front differential mounting bolt. [bolt: 21mm | nut: 22mm]

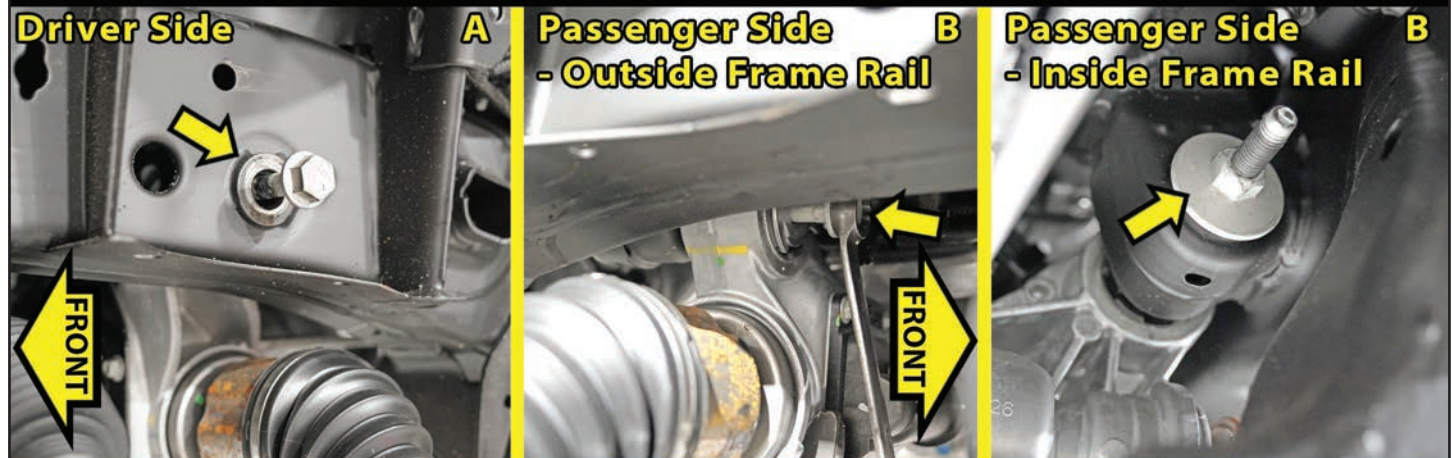
[Illustration 15]**Disconnect DR & PA Differential Front Mounts & Remove Differential...**

TECH TIP To remove the PA side bolt, push the differential to the PA side slightly and roll the back of the differential upward.

- [Illustration 15-C] Disconnect vent hose from the differential located on top of the housing just. Carefully lower the differential housing out from under the vehicle. Retain factory hardware.

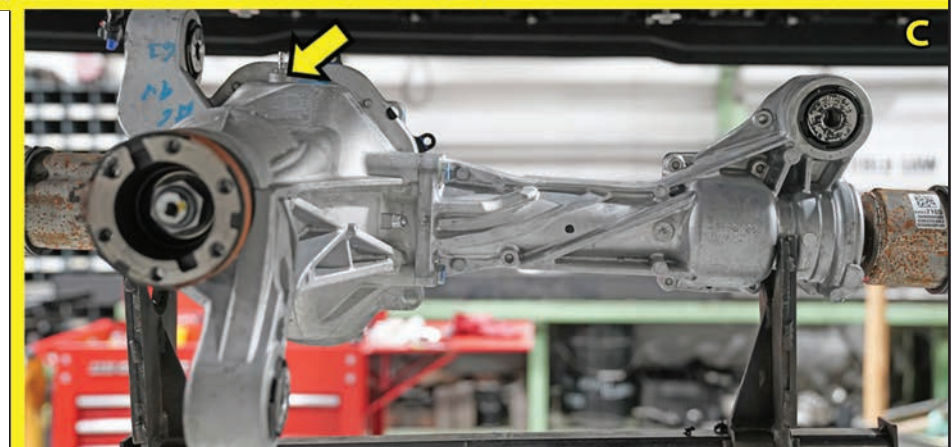

16. TRIMMING THE FRAME - REAR CROSSMEMBER MOUNTS...

⚠ NOTE: The following trimming process is performed **ONLY** on the **DR Side**.

☐☐ [Illustration 16-A] On the driver side rear lower control arm mount, measure over from the inside edge of the crossmember mount to the outside 3 Inches and mark. **🔧 TECH TIP** To get a clean mark that will not disappear or melt away during the trimming process, use a scraper to remove the cosmoline coating.

☐☐ [Illustration 16-B & 16-C] Using a square or straight edge, mark a vertical line up the crossmember mount. REPEAT Steps on the front side of the mount.

☐☐ [Illustration 16-D] Using a square or straight edge, mark a horizontal line from front to back to match your vertical line.

☐☐ [Illustration 16-E & 16-F] Cut the marked line all the way around the mount. Using a torch, plasma cutter, or similar tool, trim the lower control arm mount.

🚫 CAUTION: When using a torch or plasma cutter, beware of the sticky, waxy undercoating - cosmoline. This will melt and drip during the cutting process. Take precautions to cover your person and the floor from this extremely HOT material.

☐☐ [Illustration 16-G, 16-H & 16-I] Once you are happy with the cuts, deburr the edges with a grinder and apply a coat of paint or undercoating to prevent rust.

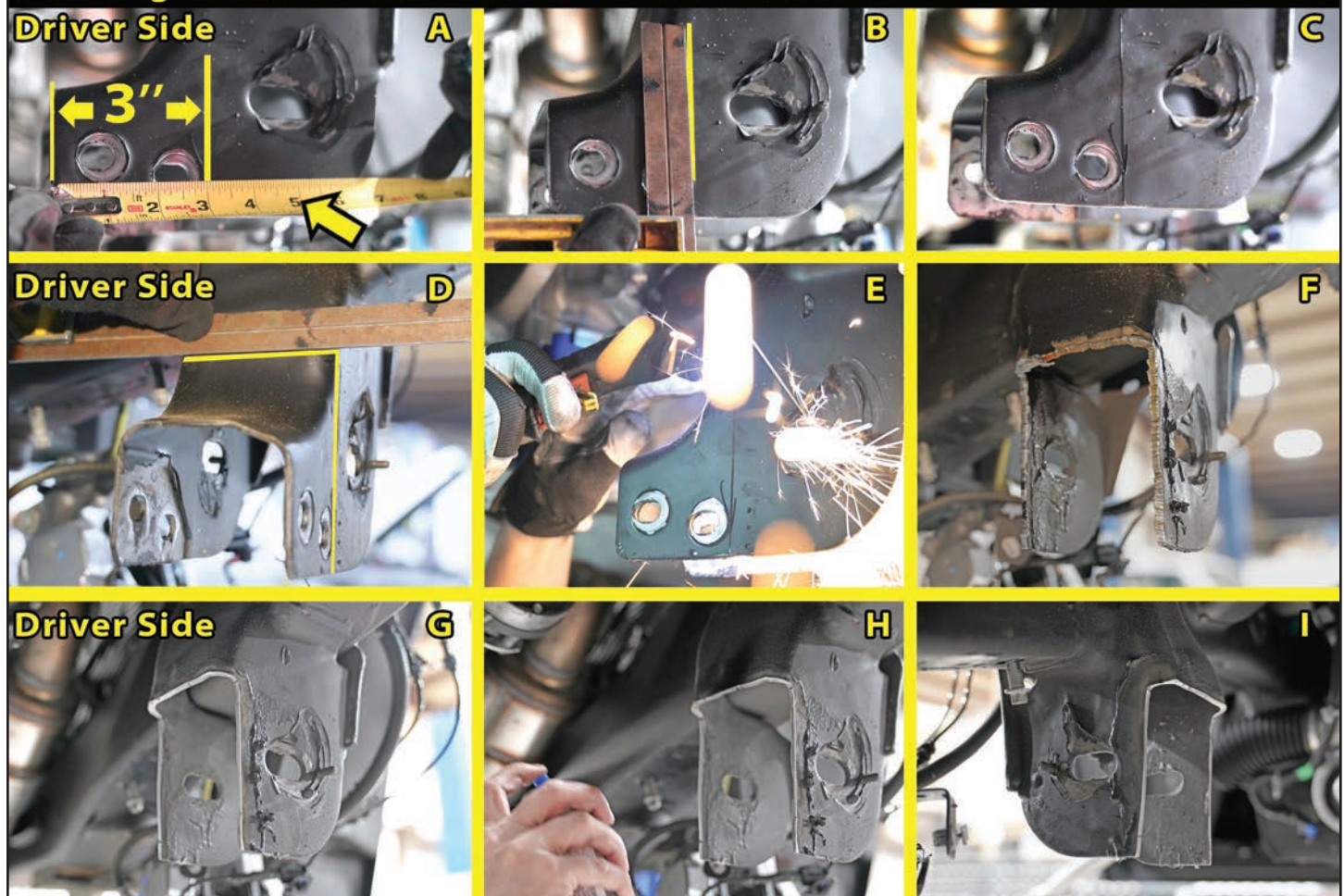
[Illustration 16]**Trimming the Frame - Rear Crossmember Mounts...**

FRONT ASSEMBLY

17. INSTALL FRONT DIFFERENTIAL BRACKETS...

Locate the SUPERLIFT Differential Drop, Driver Side (#55-03-3590), Differential Drop, Passenger Side (55-04-3590) & the Differential Support Drop, Passenger Side (#55-10-3590).

Locate Hardware Bag #77-3591. DR Side Hardware PER Side: (1) 9/16" x 4" Bolt, Course Thread, (1) 9/16" Nut, Nyloc Coarse Thread & (2) 9/16" Washer, SAE.

PA Side Hardware PER Side: (1) 9/16" x 4" Bolt, Coarse Thread, (1) 9/16" Nut, Nyloc Coarse Thread, (2) 9/16" Washer, SAE, (1) 5/8" x 5" Bolt, Coarse Thread, (1) 5/8" Nut, Nyloc Coarse Thread, (2) 5/8" Washer, SAE, (2) 1/2" x 1-1/2" Bolt, Coarse Thread, (2) 1/2" Nut, Nyloc Coarse Thread & (4) 1/2" Washer, SAE.

□ [Illustration 17-A] Attach the DR side (#55-03-3590) bracket to the factory mount with factory bolt. Do not tighten at this time. [21mm]

□ [Illustration 17-B] Attach the PA side (#55-04-3590) drop bracket to the rear of the upper factory mount. Using the supplied 5/8" x 5" Bolt, 5/8" SAE Washers & 5/8" Nyloc Nut. Insert a washer onto the bolt, run the bolt from rear-to-front through the bracket and mount. Line up the diff support bracket (# 55-10-3590) onto the bolt. **NOTE:** Notch goes to TOP. Attach with washer and Nyloc nut. Do not tighten at this time. [15/16"]

□ [Illustration 17-B] Attach the lower portion of the PA diff bracket to the rear crossmember mount using the supplied 1/2" x 1-1/2" Bolts, 1/2" SAE Washers & 1/2" Nyloc Nuts. Insert a washer onto the bolt, run the bolt from front-to-rear through the bracket and mount. Attach with washer and Nyloc nut. Do not tighten at this time. [3/4"]

□ [Illustration 17-C] Using a jack, raise the differential into position & line up the mounting holes with the new differential drop brackets.

Locate Hardware Bag #77-3592A. 3/16" x 4" Vacuum Hose, 3/16" Hose Adapter. Attach the supplied vent hose adapter to the factory vent hose. Connect the supplied vent tube to the adapter and reconnect vent tube to the differential.

[Illustration 17]

Install DR Front Differential Bracket...

Driver Side

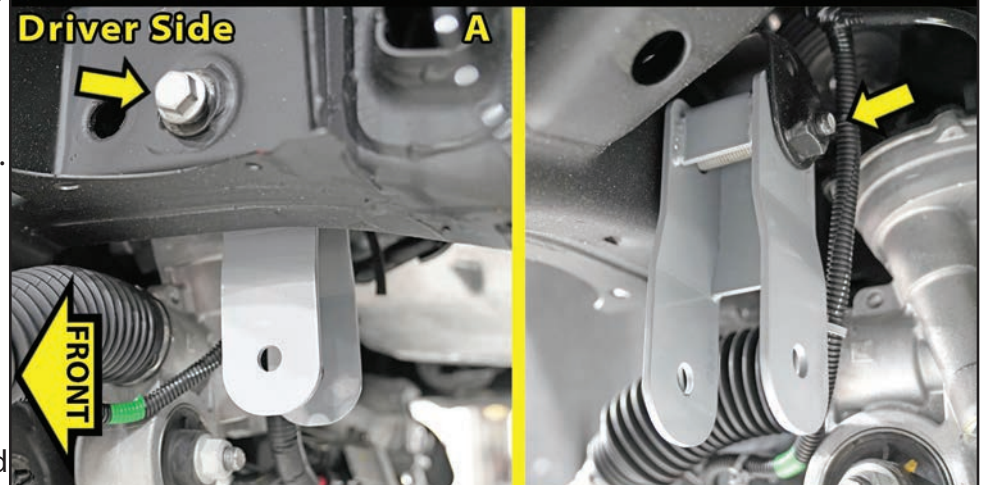

Install PA Front Differential Bracket...

Passenger Side

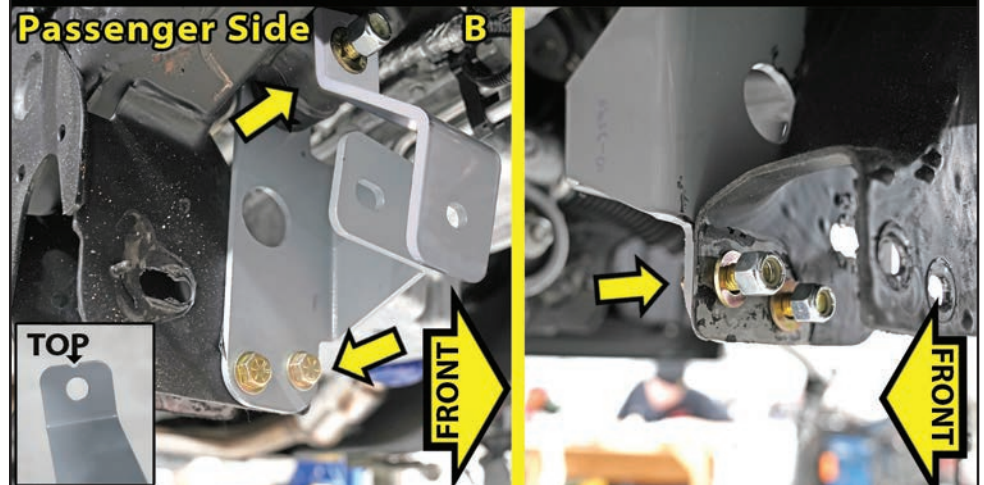

Install Differential Vent Tube Extension...

Driver Side



□ [Illustration 17-D] Attach the differential on the DR side using the supplied 9/16" x 4" Bolt, 9/16" SAE Washers and 9/16" Nyloc nut. Insert a washer onto the bolt, run the bolt from outside-to-inside through the frame, bracket, differential and mount. Attach with washer and Nyloc nut. Do not tighten at this time. [13/16" | 7/8"]

□ [Illustration 17-E] Attach the differential on the PA side using the supplied 9/16" x 4" Bolt, 9/16" SAE Washers and 9/16" Nyloc nut. Insert a washer onto the bolt, run the bolt from rear-to-front through the diff drop bracket, differential and support bracket. Attach with washer and Nyloc nut. Do not tighten at this time. [13/16" | 7/8"]

[Illustration 17]

Install Differential into DR & PA Bracket...

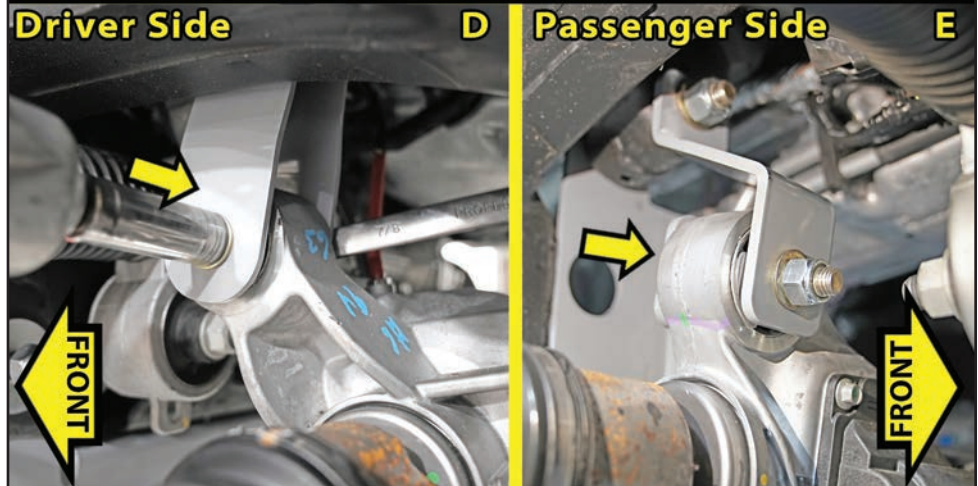

□ [Illustration 17-E] Attach the differential on the PA side using the supplied 9/16" x 4" Bolt, 9/16" SAE Washers and 9/16" Nyloc nut. Insert a washer onto the bolt, run the bolt from rear-to-front through the diff drop bracket, differential and support bracket. Attach with washer and Nyloc nut. Do not tighten at this time. [13/16" | 7/8"]

18. INSTALL REAR CROSSMEMBER & DIFFERENTIAL REAR MOUNT...

Locate the SUPERLIFT Rear Crossmember (#55-06-3590).

Locate Hardware Bag #77-3593. Hardware PER Side: (2) 18mm x 130mm Bolt, 2.5 Pitch, (4) 55-16-3590 - Lockout Washer, (2) 18mm Nut, Nyloc 2.5 Pitch, (1) 9/16" x 4" Bolt, Coarse Thread, (2) 9/16" Washer, SAE and (1) 9/16" Nut, Nyloc Coarse Thread

□ [Illustration 18-A & 18-B] First place one (1) #55-16-3590 - Lockout Washer on the front & back side of the factory DR & PA side of the LCA mounts. The small hole in the lockout washer will align onto the pin.

Install the rear crossmember (#55-06-3590) into the rear LCA mounts. The offset bend goes to the front and the diff mount goes to the rear. **TECH TIP** Hang the PA side first, then swing the DR side up and into position to also align the rear differential mount.

Secure the crossmember to the LCA mounts using the supplied 18mm x 130mm Bolt, Lockout Washers and Nyloc nuts. The bolts should be installed from rear-to-front. [27mm] Do not tighten at this time.

□ [Illustration 18-C] Secure the rear differential mount to the crossmember using the supplied 9/16" x 4" Bolt, 9/16" SAE Washer and 9/16" Nyloc Nut. Insert a washer onto the bolt, run the bolt from outside-to-inside through the diff mount, differential and mount. Attach with washer and Nyloc nut. Do not tighten at this time. [13/16" | 7/8"]

[Illustration 18]

Install Rear Crossmember & Differential Rear Mount...

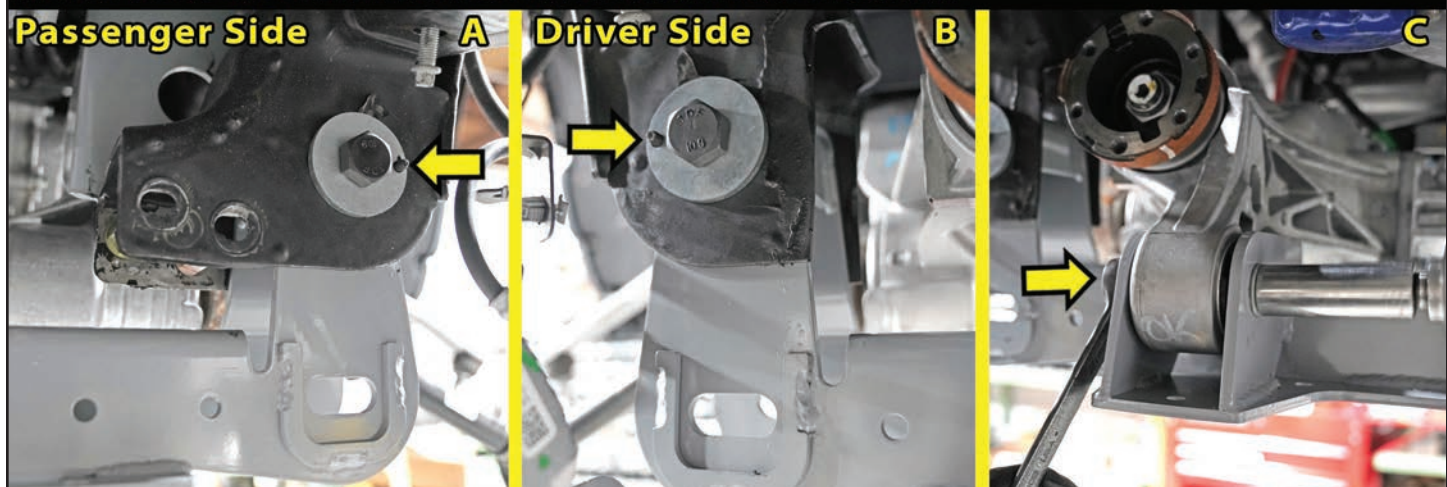

19. INSTALL FRONT CROSSMEMBER...

Locate the SUPERLIFT Front Crossmember (#55-05-3590). Locate Hardware Bag #77-3593. Hardware PER Side: (2) 18mm x 130mm Bolt, 2.5 Pitch, (4) 55-16-3590 - Lockout Washer & (2) 18mm Nut, Nyloc 2.5 Pitch

☐ [Illustration 19] First place one (1) #55-16-3590 - Lockout Washer on the front & back side of the factory DR & PA side of the LCA mounts. The small hole in the lockout washer will align onto the pin.

Install the front crossmember (#55-05-3590) into the front LCA mounts. The offset bend goes to the front.

Secure the crossmember to the LCA mounts using the supplied 18mm x 130mm Bolt, Lockout Washers and Nyloc nuts. The bolts should be installed from front-to-rear. [27mm] Do not tighten at this time.

[Illustration 19]**Install Front Crossmember...****Passenger Side****Driver Side****20. TIGHTEN PA SIDE FRONT DIFFERENTIAL BRACKETS...**

☐ [Illustration 20-A] Starting with the PA side differential bracket first, tighten the upper bracket to frame mount. [15/16"]

☐ [Illustration 20-B] Tighten the lower two (2) bolts on the bracket to LCA mount. [3/4"]

☐ [Illustration 20-C] Tighten the differential to the bracket and support bracket. [13/16" | 7/8"]

TECH TIP You can access the bolt with an impact socket through access hole in the bracket.

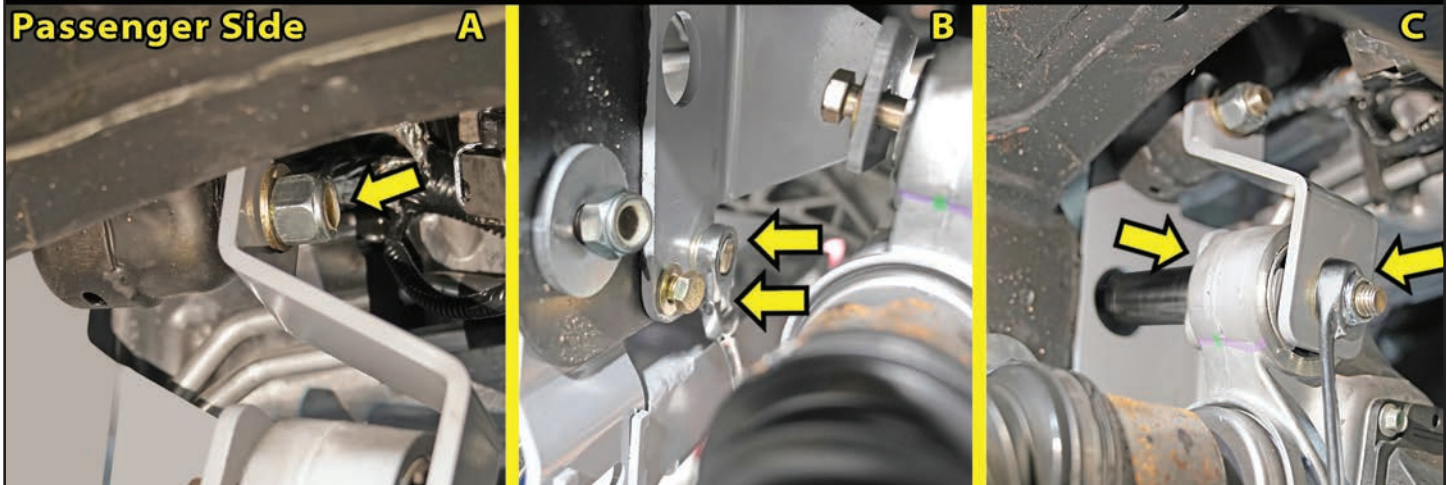
[Illustration 20]**Tighten DR & PA Front Differential Mounting Brackets...****Passenger Side****A****B****C**

21. TIGHTEN DR SIDE FRONT DIFFERENTIAL BRACKET & RECONNECT PLUGS...

- [Illustration 21-A] On the DR side lower mount, tighten the differential to the bracket. [13/16" | 7/8"]
- [Illustration 21-B] On the DR side upper mount, tighten the bracket to the frame. [21mm]
- [Illustration 21-B] Carefully plug the bottom three (3) plugs back into the rack and pinion. **⚠ NOTE:** On the PA side, follow the wire loom up from the differential actuator and unclip the wire loom clips from the frame to gain any slack needed to reconnect the plug to the differential actuator. Plug the single differential actuator connector back into place. Zip tie the wire loom safely up as needed to prevent damage.

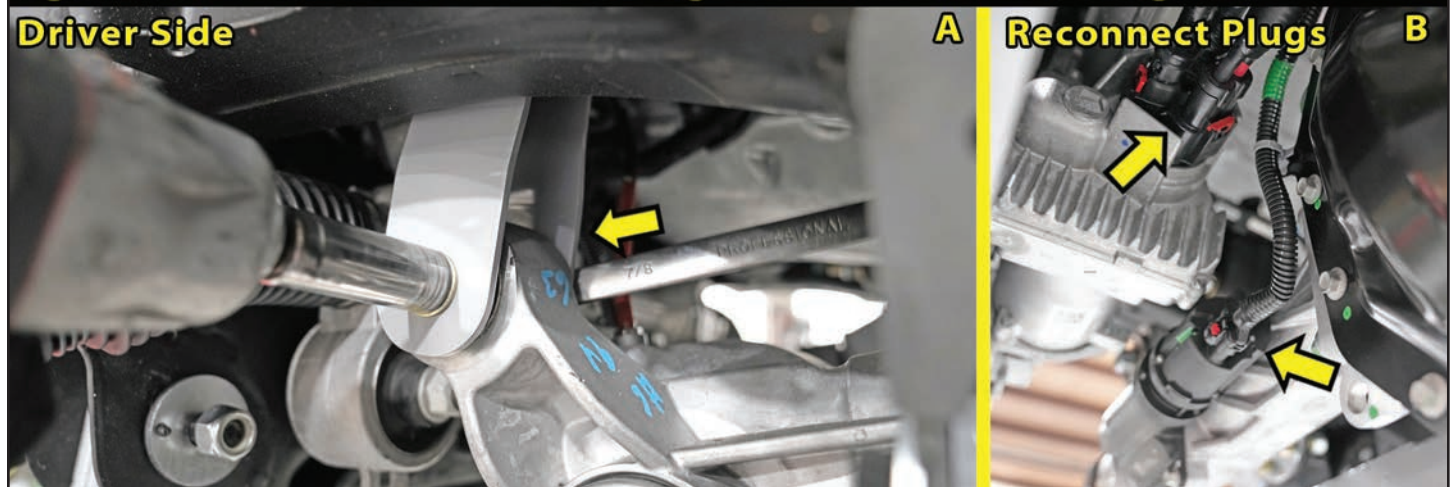
[Illustration 21]**Tighten DR Front Differential Mounting Bracket & Reconnect Plugs...****22. INSTALL LCA INTO CROSSMEMBERS...**

Locate Hardware Bag #77-3593. Hardware PER Side: (2) #55-13-3590 - Cam Bolt, (4) #55-21-9940 - Cam Washers & (2) 18mm Nut, Nyloc 2.5 Pitch

- [Illustration 22-A] Install the lower control arms into the new crossmembers with the supplied alignment cam bolts and nuts. Make sure the cam washers fit between the control tabs on the crossmembers. The cam washer should be in the up or neutral position.

[Illustration 22-B] Insert the front cam bolt in from front-to-rear.

[Illustration 22-C] Insert the rear cam bolt in from rear-to-front.

Snug, but do not tighten. [27mm]

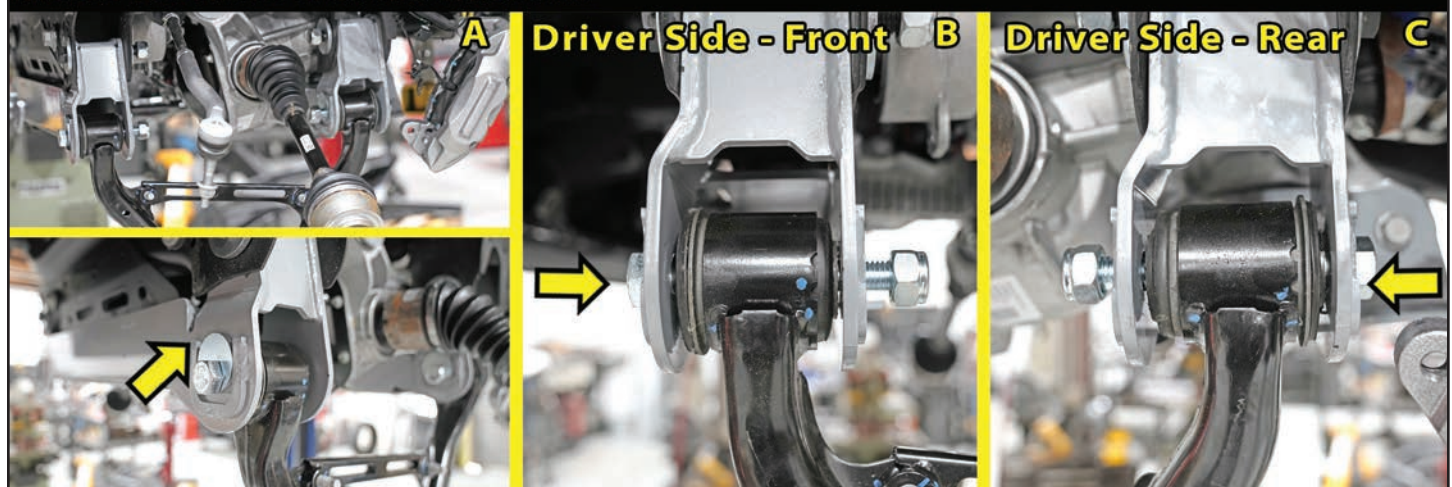
[Illustration 22]**Install LCA into Crossmembers...**

23. TIGHTEN CROSSMEMBERS TO FRAME & REAR DIFF MOUNT TO CROSSMEMBER...

Tighten these bolts in this order.

- [Illustration 23-A] Rear crossmember mounting bolts to frame. (280) [27mm]
- [Illustration 23-B] Differential rear mounting bolt to rear crossmember. (105) [bolt 13/16", nut 7/8"]
- [Illustration 23-C] Front crossmember to frame (280) [27mm]

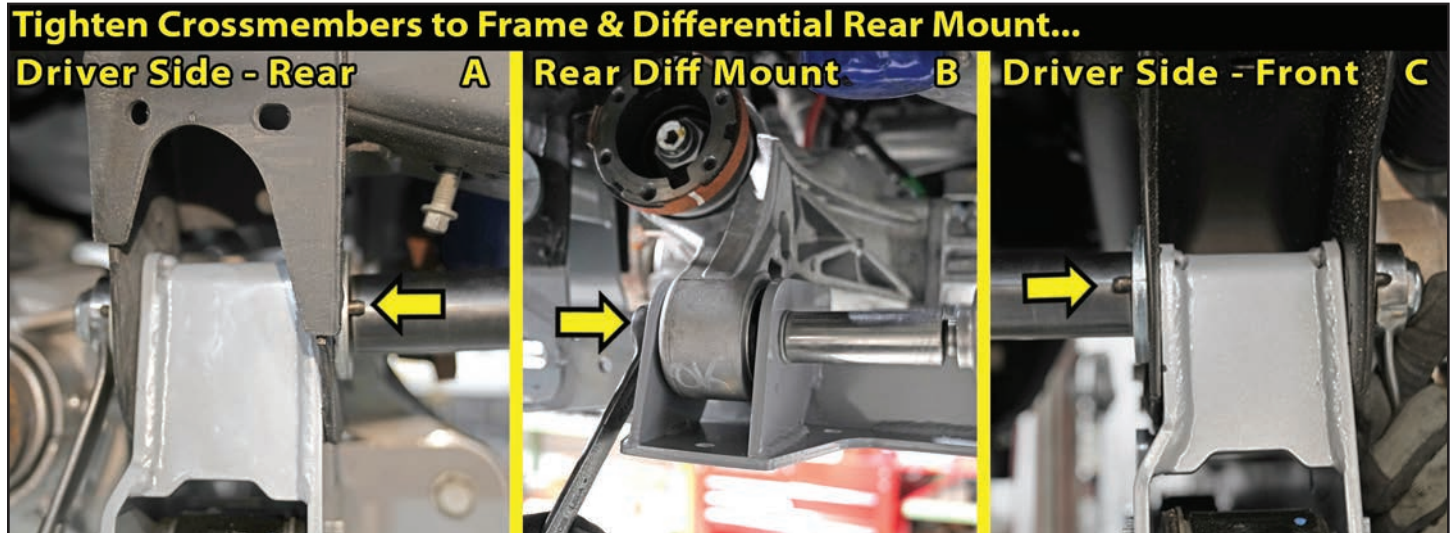
[Illustration 23]**24. RECONNECT FRONT DRIVESHAFT...**

Locate Hardware Bag #77-3592A. Locate #F470L Thread Locker #27105.

- [Illustration 24] Apply thread locker to the factory six (6) bolts. Line up the front driveshaft with the differential yoke according to the marks made during removal and secure using the factory bolts and securing plates. Tighten (19) [10mm]

[Illustration 24]

25. ASSEMBLE STRUT SPACER ONTO STRUT ASSEMBLY...

Locate the (2) SUPERLIFT Strut Spacers (#55-07-3590). Locate Hardware Bag #77-3591. Hardware PER Side: (3) 10mm x 35mm Bolt, Carriage 1.5 Pitch, (3) 10mm Nut, Flange & (3) 10mm Push Nuts.

☐☐ [Illustration 25-A] Insert the supplied 10mm x 35mm Carriage Bolt up through the square hole in the top of the strut spacer. Secure the carriage bolt into place with the 10mm Push Nuts. **TECH TIP** You can use your fingers to work the push nut down and locked into place. You can also use a socket.

☐☐ [Illustration 25-B] Align the strut spacer (#55-07-3590) with the notches facing the outside of the vehicle. [Illustration 25-C] Secure to the top of the strut assembly using the supplied 10mm Flange Nuts. Tighten securely. (37) [15mm]

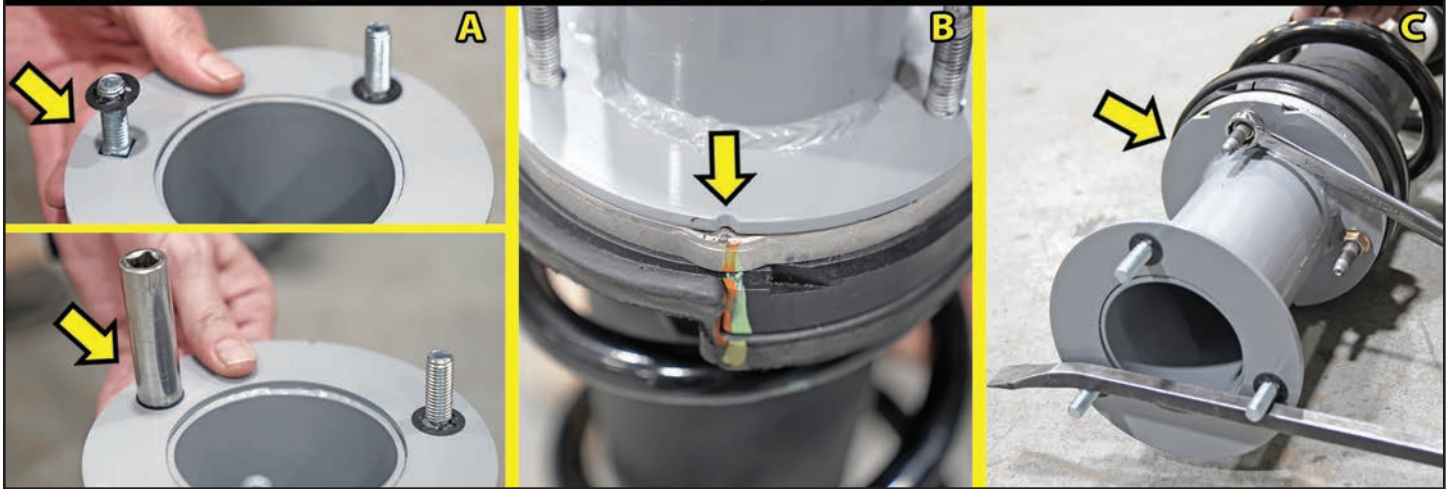
[Illustration 25]**Assemble Strut Spacer onto Strut Assembly...****26. INSTALL STRUT | SPACER ASSEMBLY...**

☐☐ [Illustration 26-A] Slide the strut assembly through the upper control arm and locate the upper end of the assembly into the frame mount properly. Secure the three (3) upper end bolts of the assembly using the factory flange nuts. Do not tighten at this time. [18mm]

☐☐ [Illustration 26-B] Attach the lower end of the strut to the lower control arm using the factory hardware and tighten. (37) [15mm]

☐☐ [Illustration 26-C] Tighten the top strut flange nuts. (37) [15mm]

☐☐ [Illustration 26-D] Connect the factory wire clips located back to the top of the studs.

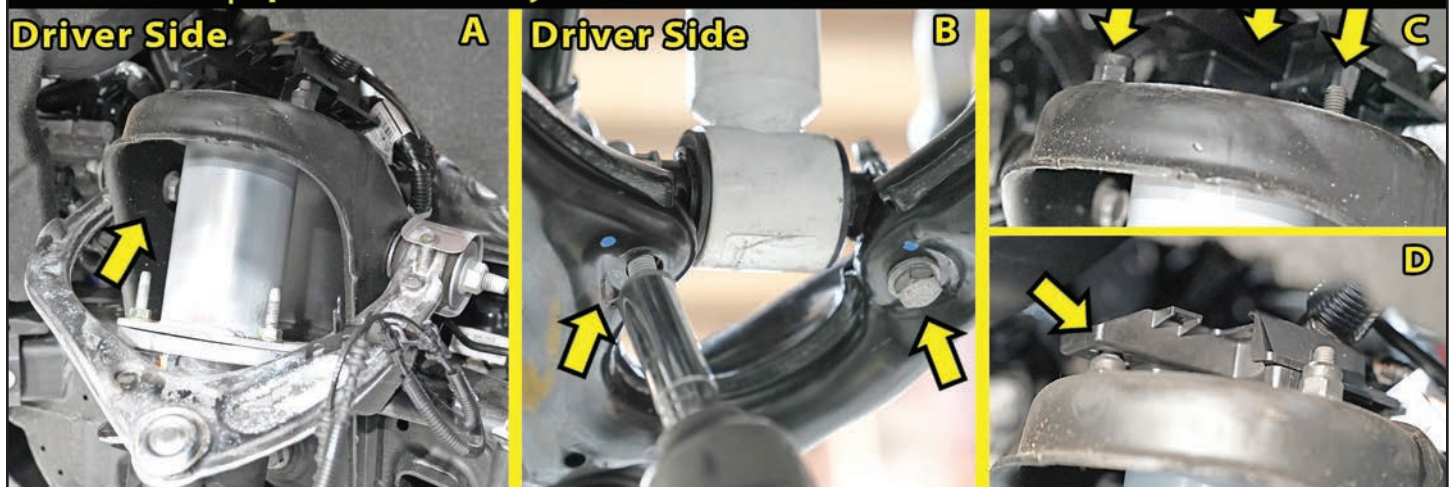
[Illustration 26]**Install Strut | Spacer Assembly...**

27. INSTALL SWAY BAR BRACKETS AND SWAY BAR ASSEMBLY...

Locate the SUPERLIFT Sway Bar Drops (#55-11-3590) DR Side & (#55-12-3590) PA Side. Locate Hardware Bag #77-3591. Hardware PER Side: (2) 3/8" x 1-1/4" Bolt, Coarse Thread, (2) 3/8" Nut, Nyloc Coarse Thread & (4) 3/8" Washer, SAE.

[Illustration 27-A] On the SUPERLIFT drop brackets, the 'Notch' goes to the front of the vehicle. Attach the (#55-11-3590) sway bar drop bracket to the DR side using the factory hardware. Secure the (#55-12-3590) to the PA side using the factory hardware. [10mm]

[Illustration 27-B] Locate the factory sway bar assembly. Note the specific side via your marks.

⚠ NOTE: The sway bar assembly Must Be "Flipped" or installed upside down from the original position. Attach the factory DR side frame mount to the PA side drop bracket and the factory PA side to the DR side. Secure to the drop brackets with the supplied 3/8" x 1-1/4" Bolt, 3/8" Nyloc Nuts & 3/8" SAE Washers. Insert a washer onto the bolt, run the bolt from up through the factory mount into the drop bracket and attach with washer and Nyloc nut. [9/16"]

[Illustration 27-C] Swing the sway bar assembly into position, so the factory sway bar links align into the factory position on the LCA. Secure, but do not tighten. [18mm]

[Illustration 27]

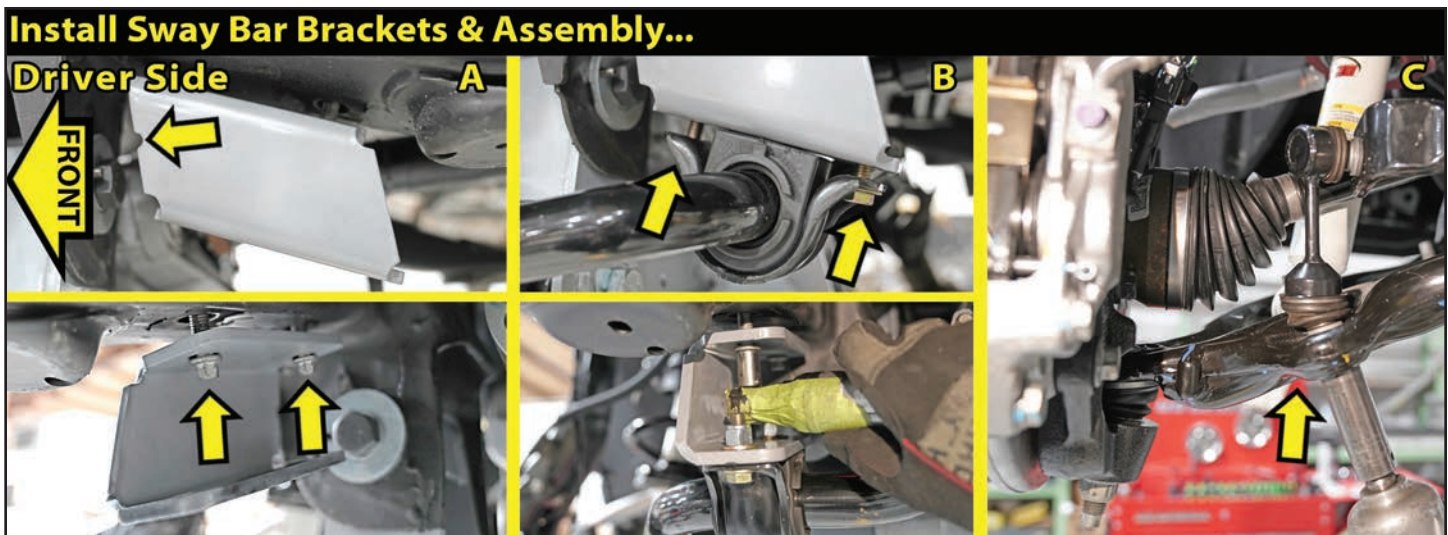

28. KNUCKLE ASSEMBLY...

⚠ NOTE: Perform these Steps on One Knuckle at a Time.

Locate the (2) SUPERLIFT Knuckles (#66-01-3590) DR Side & (#66-02-3590) PA Side. Locate Hardware Bag #77-3590. Hardware PER Side: (1) F470L, Thread Locker

[Illustration 28-A] Note the orientation of the dust shield and wheel bearing assembly prior to removal.

[Illustration 28-B] Remove the four (4) bolts securing the wheel bearing assembly to the factory knuckle. [18mm] Transfer the factory ABS and brake line bracket bolts from the stock knuckle to the new knuckle.

[Illustration 28-C] Make sure the O-ring on the wheel bearing assembly is still in the correct position and that it is not torn or worn.

[Illustration 28-D] Remove the O-ring from the factory knuckle. [mechanic pick]

[Illustration 28-E] Carefully install the O-ring from the factory knuckle into the SUPERLIFT knuckle.

[Illustration 28-F] Apply thread locker to the factory four (4) bolts. Install the dust shield and wheel bearing assembly onto the SUPERLIFT Knuckle (#66-01-3590) DR Side & (#66-02-3590) PA Side **⚠ NOTE:** Be sure the orientation of the dust shield and bearing assembly matches original. Tighten. (151) [18mm]

[Illustration 28]

Knuckle Assembly...

Driver Side

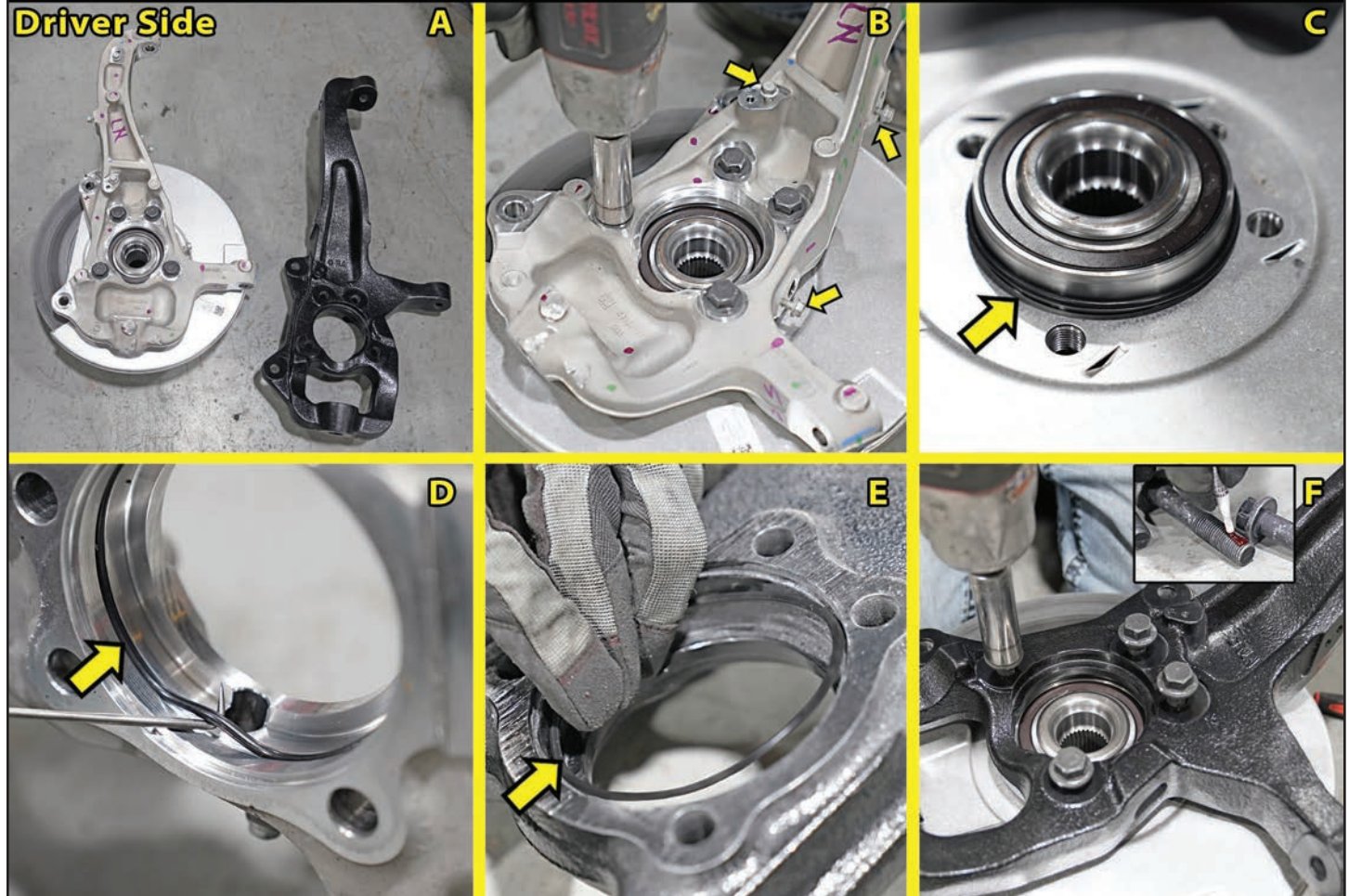

29. INSTALL KNUCKLE ASSEMBLY...

☐☐ [Illustration 29-A] Position the new knuckle on the LCA ball joint while sliding the CV shaft into the new knuckle. Install the factory nut onto the LCA ball joint. Secure, but do not tighten. [24mm]

☐☐ [Illustration 29-B] Attach the tie rod to the knuckle for stability. Hand tighten only.

☐☐ [Illustration 29-C] Attach the upper ball joint to the knuckle. Secure, but do not tighten. [18mm]

TECH TIP If needed, use a pry bar to lower the upper control arm to attach the ball joint.

☐☐ Tighten the lower ball joint nut (94) and the upper ball joint nut (37).

[Illustration 29]

Install Knuckle Assembly...

Driver Side

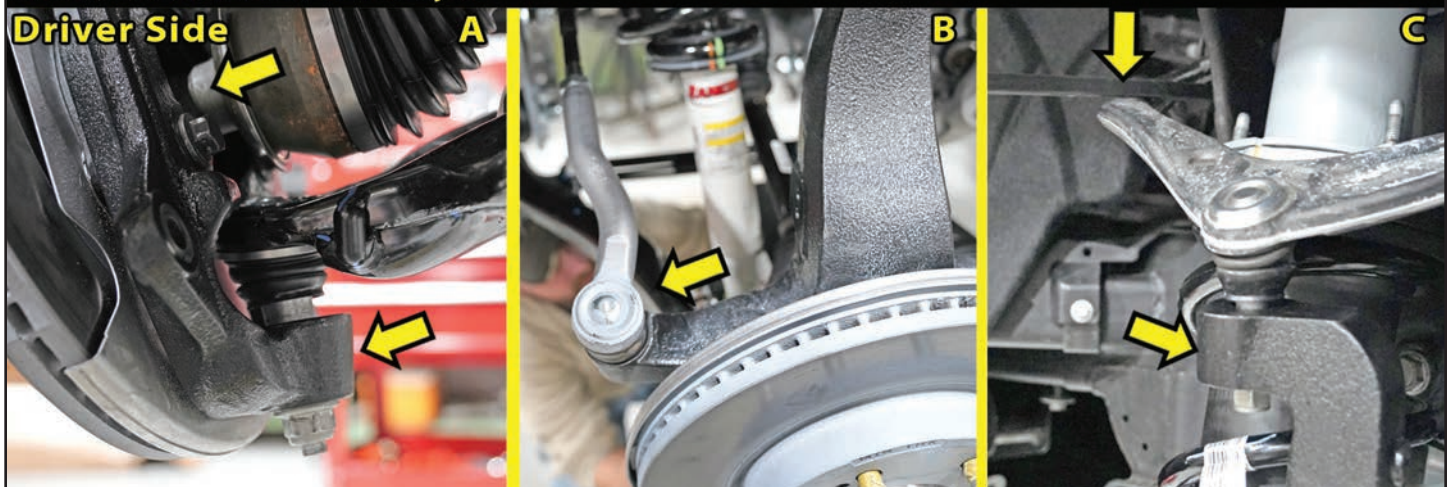

30. INSTALL CV AXLE SHAFT NUT & BRAKE ROTOR...

☐☐ [Illustration 30] Secure the axle shaft to the knuckle with the factory nut. Tighten. (148-165) [36mm] Install the brake rotor to the hub assembly and reinstall the factory torx retaining bolt. [T30]

31. INSTALL BRAKE CALIPER TO KNUCKLE...

☐☐ [Illustration 31] Reattach the brake caliper to the rotor. Apply thread locker to the two (2) factory bolts and attach the brake caliper to the knuckle. [18mm] Plug in brake pad wear sensor into the caliper.

[Illustration 30]

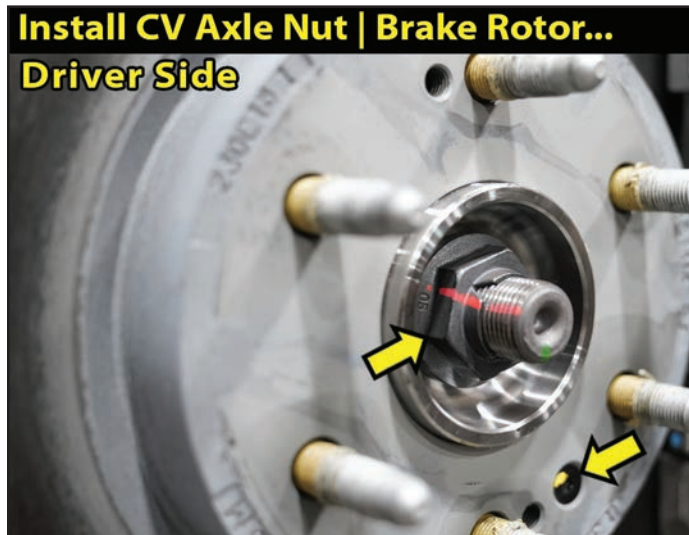

32. STEERING TIE ROD END...

☐☐ [Illustration 32] Tighten the tie rod end to the knuckle. (44) [21mm]

[Illustration 31]

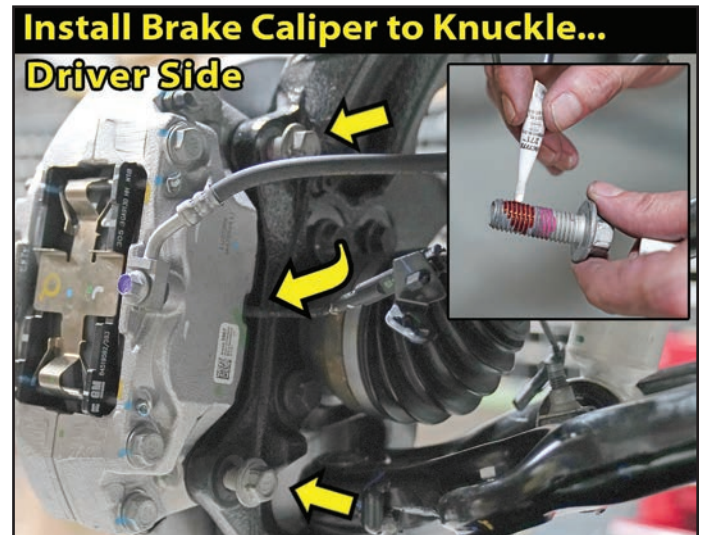

[Illustration 34]



33. ATTACH ABS & BRAKE LINE BRACKETS TO KNUCKLE...

NOTE: The routing of the ABS & brake lines are DR & PA side specific & vary side-to-side.

Locate Hardware Bag #77-3590. Hardware PER Side: (3) 3/8" Adel Clamp.

Driver Side Steps

- [Illustration 33-A] Below the tie rod boss on the knuckle, attach the ABS line to the knuckle with the factory bolt. [10mm]
- [Illustration 33-B] Follow the ABS line up the front of the knuckle, attach the ABS line bracket tab into the knuckle and secure with the factory bolt. [10mm]
- [Illustration 33-C] First, attach the ABS/brake pad wear sensor bracket to the inward side of the knuckle with the factory bolt. [10mm] Next, attach the brake line bracket to the rear side of the knuckle with the factory bolt. [10mm] Make sure the ABS/brake pad wear sensor line is attached to the brake line bracket.
- [Illustration 33-D] Unplug the two (2) the ABS/brake pad line clips from the bracket on the upper control arm.
- [Illustration 33-E] Follow the two (2) ABS/brake pad lines downward and remove them from the bracket that attached to the factory knuckle.
- [Illustration 33-F] Use the two (2) supplied Adel clips to attach the two (2) ABS/brake pad lines to the rear of the upper neck of the knuckle with the factory bolt. [10mm]

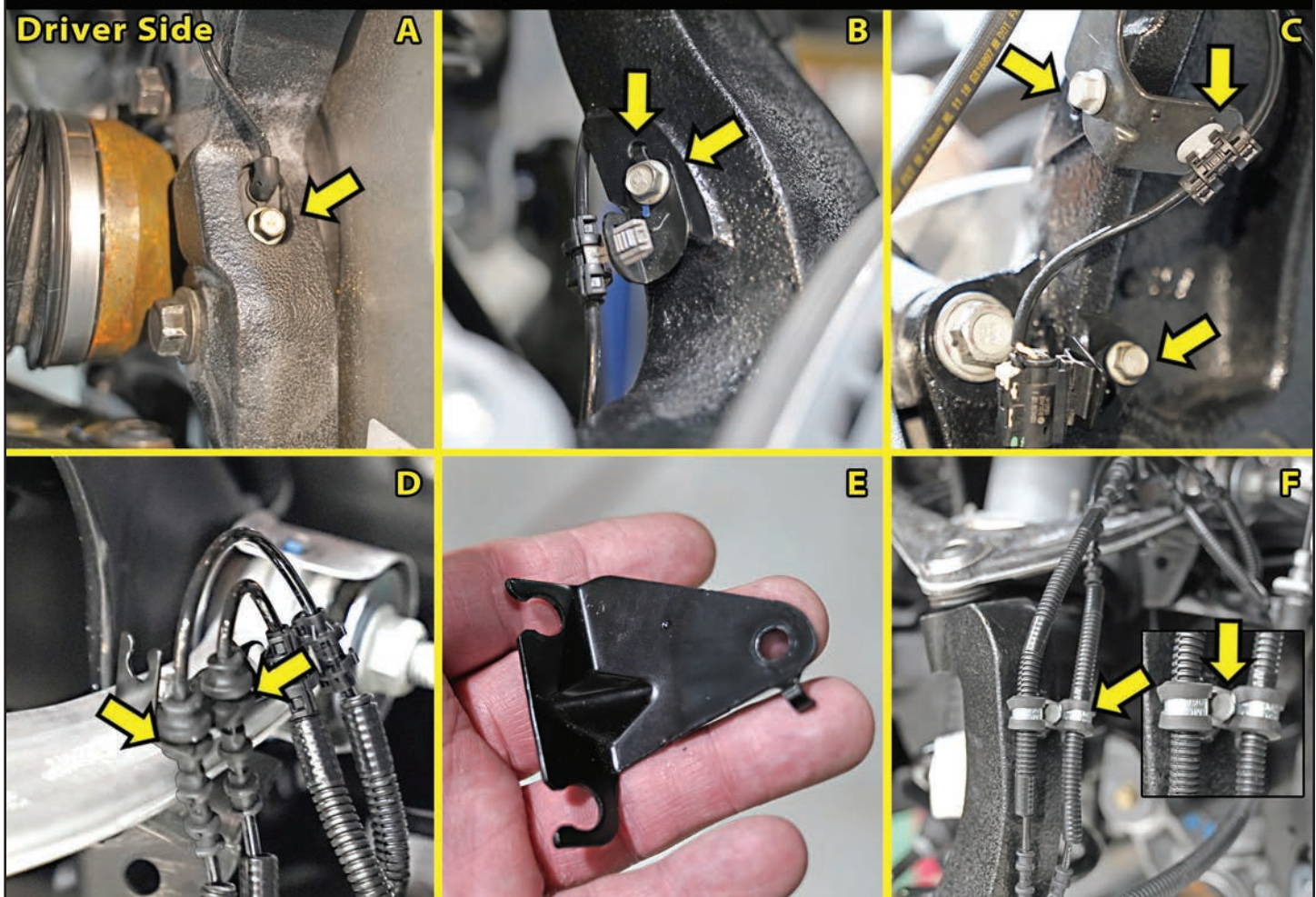
[Illustration 35]**Attach ABS & Brake Line Brackets to New Knuckle...**

Passenger Side Steps

Locate Hardware Bag #77-3590. Hardware PER Side: (3) 3/8" Adel Clamp.

☐☐ [Illustration 33-G] Below the tie rod boss on the knuckle, attach the ABS line to the knuckle with the factory bolt. [10mm]

☐☐ [Illustration 33-H] Follow the ABS line up the front of the knuckle, attach the ABS line bracket tab into the knuckle and secure with the factory bolt. [10mm]

☐☐ [Illustration 33-I] First, locate the ABS sensor bracket that attached to the inward side of the knuckle. Next, bend the location tab on the bracket 'flat'.

☐☐ [Illustration 33-J] Follow the ABS line up to the frame (to the rear of the upper control arm and behind the wheel well liner). Unplug the two (2) the ABS line clips from inner liner.

[Illustration 35]

Attach ABS & Brake Line Brackets to New Knuckle...

Passenger Side

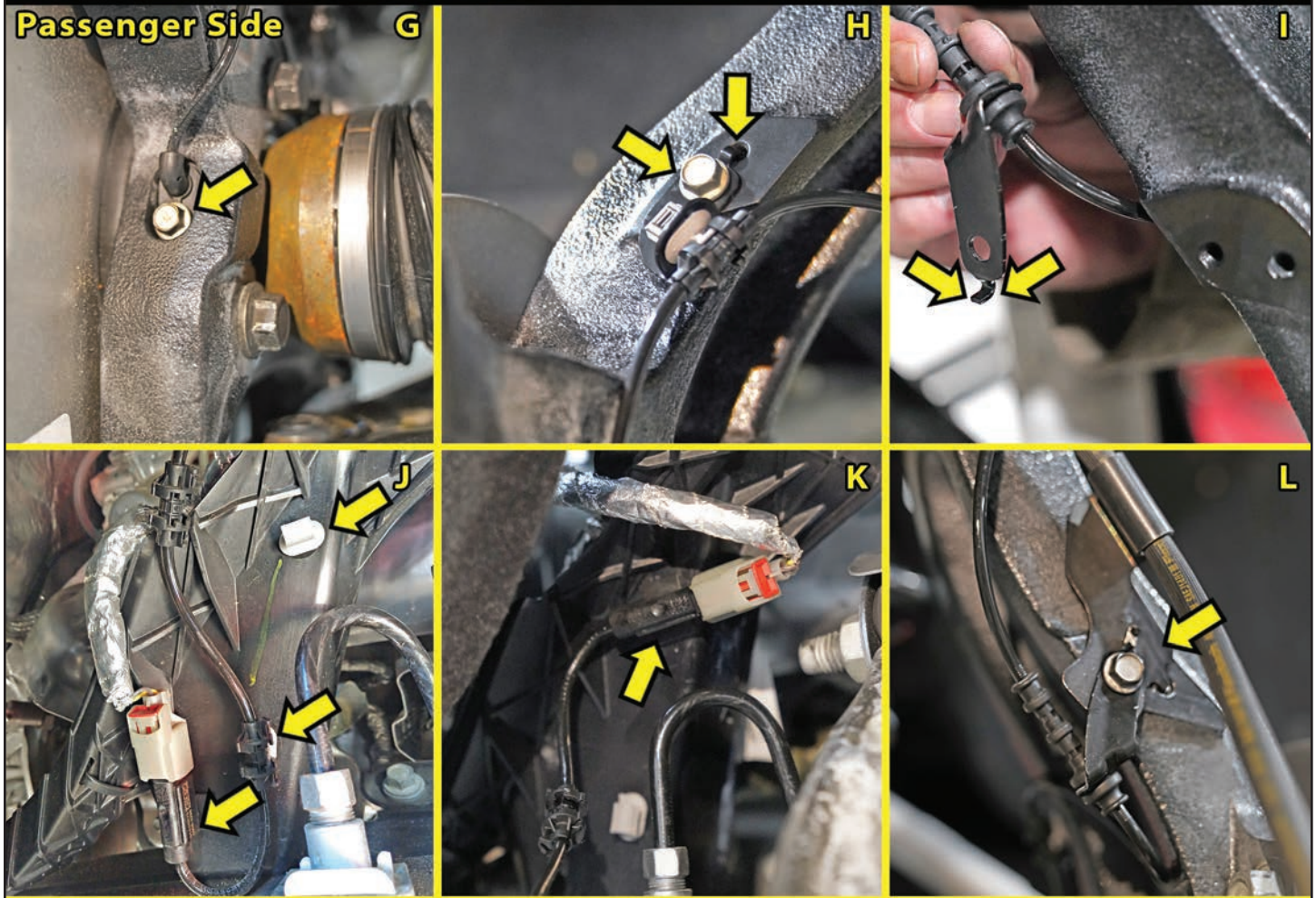

☐☐ [Illustration 33-K] To gain slack in the line, relocate the ABS clip connecting the plug to the upper white clip (note arrow in 33-J).

☐☐ [Illustration 33-L] Attach the brake line bracket and the ABS sensor bracket to the rear neck of the knuckle using the factory bolt. [10mm]

☐☐ [Illustration 33-M] Use the supplied Adel clip to attach the ABS line to the rear of the upper neck of the knuckle with the factory bolt. [10mm]

34. INSTALL BELLY PAN...

Locate the SUPERLIFT Belly Pan (#55-09-3590). Locate Hardware Bag #77-3592. Hardware PER Part: (5) 3/8" x 1" Bolt, Carriage Coarse Thread & (5) 3/8" Nut, Flange.

[Illustration 34] Attach the belly pan (#55-09-3590) to the front and rear crossmembers using the supplied 3/8" x 1" Carriage Bolts and 3/8" Flange Nuts. The front has two (2) holes and the rear has three (3) holes. Insert the carriage bolts up through the square holes in the belly pan and secure with flange nuts. Tighten. (23) [9/16"] **NOTE:** Start with the DR front carriage bolt, then swing the belly pan into place to attach one (1) of the rear mounting bolts. Proceed to install all hardware.

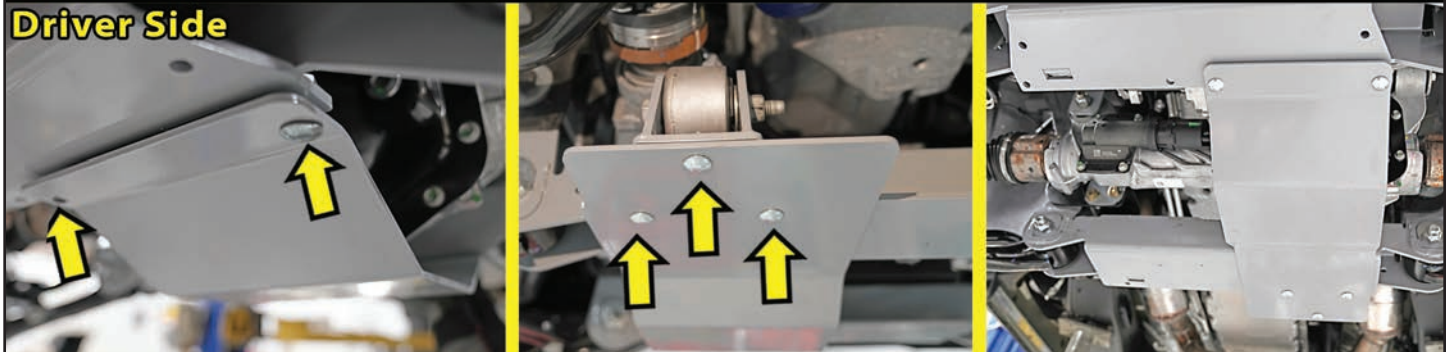
[Illustration 34]**Install Belly Pan...****Driver Side****35. TIRES / WHEELS...**

[Illustration 35] Install tires and wheels. Tighten the lug nuts in the sequence shown. (151) [21mm]

WARNING: When the tires / wheels are installed, always check for and remove any corrosion, dirt, or foreign material on the wheel-mounting surface, or anything that contacts the wheel-mounting surface (hub, rotor, etc.). Installing wheels without the proper metal-to-metal contact at the wheel mounting surfaces can cause the lug nuts to loosen and the wheel to come off while the vehicle is in motion.

WARNING: Retighten lug nuts at 500 miles after any wheel change, or anytime the lug nuts are loosened. Failure to do so could cause wheels to come off while vehicle is in motion.

Lower vehicle to the floor. The suspension is now supporting vehicle weight.

36. TIGHTEN LOWER CONTROL ARM ECCENTRIC CAM BOLTS...

[Illustration 36] Tighten the four (4) lower control arm eccentric cam bolts (2 Per Side); keep the alignment cams in the up (neutral) position until the alignment is performed. (129) [27mm]

[Illustration 35]**Lug Nut Torque Sequence...**

Follow the Sequence Below to Torque the Lug Nuts

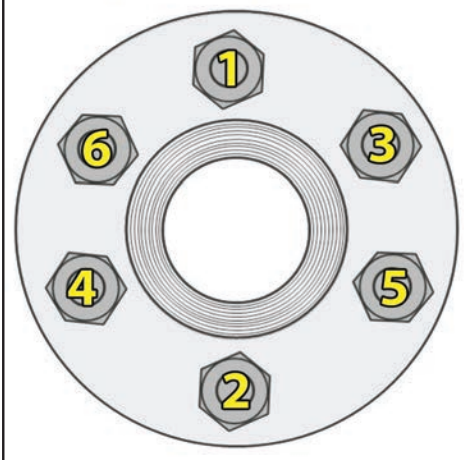
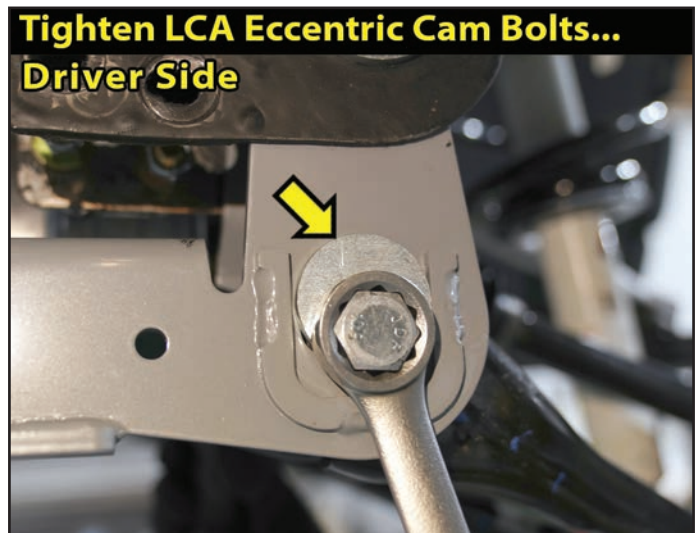
**[Illustration 36]****Tighten LCA Eccentric Cam Bolts...
Driver Side**

37. CLEARANCE CHECK...

With the vehicle on the ground, cycle the steering lock-to-lock and check all components for proper operation and clearances. Pay special attention to the clearance between the tires / wheels and knuckles, brake hoses, wiring, etc.

Raise the vehicle back onto jack stands and secure as per step 1. With the suspension "hanging" at full extension travel, cycle the steering lock-to-lock and check all components for proper operation and clearances. Pay special attention to the clearance between the tires / wheels and knuckles, brake hoses, wiring, etc. Lower the vehicle to the floor.

38. BATTERY...

Reconnect battery.

REAR DISASSEMBLY & ASSEMBLY

NOTE: Save all factory components and hardware for reuse, unless noted.

39. RAISE REAR OF VEHICLE...

Chock the front tires. Position a jack beneath the center of the rear axle of the vehicle. Raise rear of vehicle and place jack stands beneath the frame rails just forward of the rear springs' front hangers. Ease the jack down until the frame is resting on the stands. Keep a slight load on the jack.

Remove the rear tires.

40. INSTALL REAR BRAKE LINE BRACKET...

Locate the SUPERLIFT Rear Brake Line Bracket: (#55-15-3590). Locate Hardware Bag #77-3594. Hardware PER Side: (2) 5/16" x 1" Bolt, Coarse Thread, (2) 5/16" Nut, Nyloc Coarse Thread & (4) 5/16" Washer, SAE.

[Illustration 40-A] Located on the inside of the driver side frame rail near the factory bump stop, unbolt the two (2) factory bolts that attach the factory brake bracket to the frame. [13mm]

[Illustration 40-B] **NOTE:** The SUPERLIFT brake line bracket has two (2) notches: The 'notched' edge of the bracket goes toward the 'front' and to the 'top'. Attach the SUPERLIFT brake line bracket to the frame using the two (2) factory bolts and mounting holes. [13mm]

[Illustration 40-C] Attach the factory brake line bracket to the new bracket using the supplied 5/16" x 1" Bolts, 5/16" SAE Washers & 5/16" Nyloc Nuts, Insert a washer onto the bolt, run the bolt from the outside-to-inside through the bracket into the factory bracket and attach with washer & Nyloc nut. [1/2"]

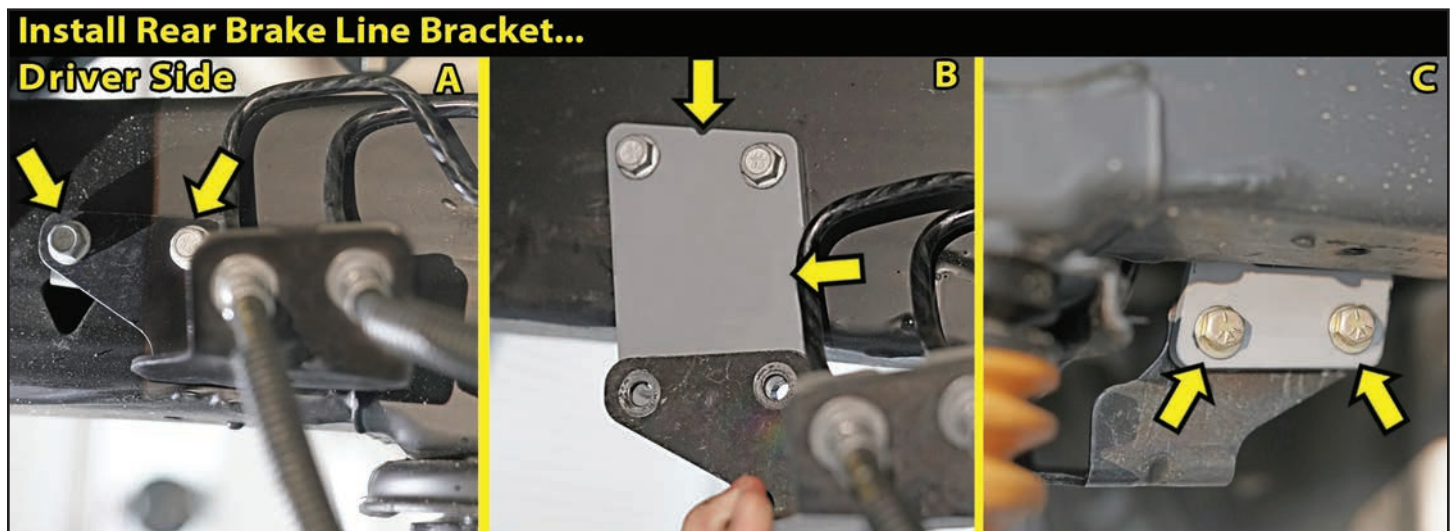
[Illustration 42

41. REMOVE SHOCK ABSORBERS...

[Illustration 41] Remove shock absorbers. Discard shocks. [21mm]

42. UBOLTS AND BLOCKS...

[Illustration 42] Remove ubolts and then lower the axle several inches away from springs. [21mm]
Discard the ubolts and hardware. Maintain the lower ubolt plate.

Clean spring pads of all debris.

[Illustration 41**[Illustration 42****43. INSTALL REAR LIFT BLOCKS AND UBOLTS...**

Locate the SUPERLIFT (2) 55-05-201 6" Rear Blocks. Locate the (4) #10482 - 9/16" x 2-1/2" x 11-1/2" Ubolt, Square. Locate Hardware Bag #77-1509. Hardware PER Side: (4) 9/16" high nut, fine thread & (4) 9/16" ubolt washers. Locate Hardware Bag #77-1507. Hardware PER Side: (2) 7/16" x 3-1/4" x 4-1/2" Ubolt, Square Fine Thread & (4) 7/16" Nut, Flange Fine Thread. Locate (1) #55-03-200 10 GA Spacer, Block Shim & (1) #55-07-200 7 GA Spacer, Block Shim

[Illustration 43-A] **⚠ NOTE:** The 'notched' edge of the block goes toward the 'front'.

[Illustration 43-B] Position the SUPERLIFT block on top of the axle pad.

[Illustration 43-C] Using the floor jack(s), mate the springs to the blocks, be sure that the center bolt heads seat properly. Install the new SUPERLIFT 9/16" ubolts, factory ubolt plate and supplied ubolt washers & high nuts. Evenly torque the ubolts using an "X" tightening sequence. (150) [7/8"]

[Illustration 43-D] **⚠ NOTE:** Because GM uses various leaf spring packs, there may be a gap in between the leaf spring and the SUPERLIFT block at the front or the rear. The gap will be consistent on the driver and passenger side.

[Illustration 43-E] SUPERLIFT supplies two (2) different block spacer shims: #55-03-200 10 GA Spacer & #55-07-200 7 GA Spacer. The spacer shims install in between the block and leaf spring and held in place by the 7/16" ubolts that go over the leaf spring and attach to the block. Your vehicle may need one (1) Per Side or it may need two (2) Per Side. Use the appropriate spacer shims to fill the gap.

[Illustration 43-F] Install the new SUPERLIFT 7/16" x 3-1/4" x 4-1/2" over the leaf spring and through the new block securing with the supplied 7/16" flange nuts. (70) [5/8"]

[Illustration 43

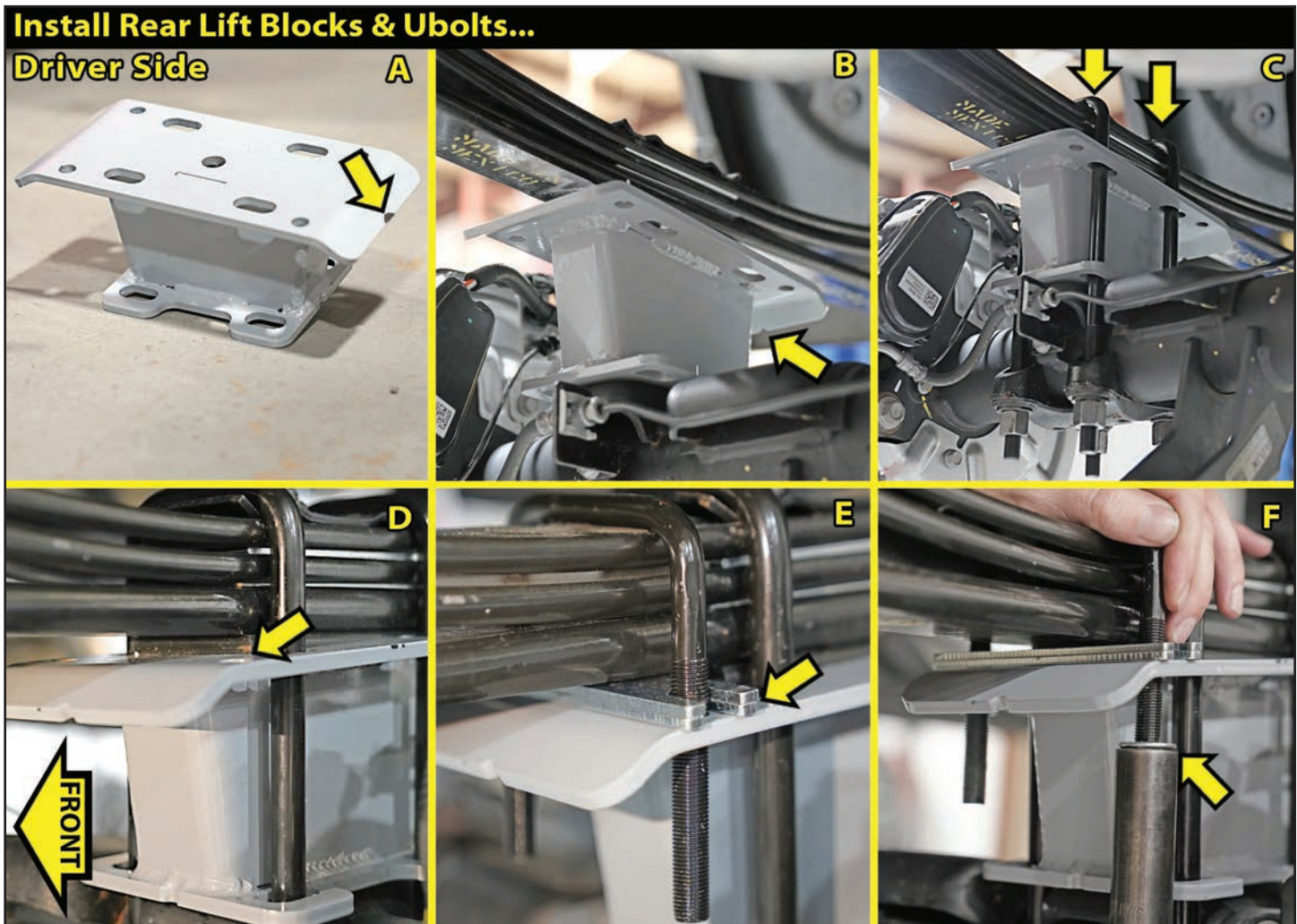
**44. INSTALL SUPERLIFT or BILSTEIN REAR SHOCK ABSORBERS...**

Locate the (2) SUPERLIFT #01-85150 (650341) Shocks **OR** the (2) BILSTEIN 5100 Series #BE5-6249-H5 Shocks.

Locate Hardware Bag #77-80033. Hardware PER Side: (2) #01-60418, Hourglass Bushings & (2) #39-3480, 0.75" OD x 0.5630" ID x 1.68" L, Sleeve & (2) 3/4" Washer, SAE.

[Illustration 44-A & 44-B] If installing the SUPERLIFT shocks, install the supplied #01-60418 hourglass bushings into the shock eyes. Then install the #24-5704, 0.75" OD x 0.50" ID x 1.54" Long sleeves into the shock eyes.

[Illustration 44-A & 44-B] If installing the BILSTEIN shocks, first press out the bushings. Then install the supplied #01-60418 hourglass bushings into the shock eyes. Then install the #24-5704, 0.75" OD x 0.50" ID x 1.54" Long sleeves into the shock eyes.

[Illustration 44-C] Install the new shocks (SUPERLIFT #01-85150 or BILSTEIN 5100 SERIES #BE5-6249-H5) into the factory location with the factory hardware. [21mm] (55)

⚠ NOTE: SUPERLIFT brand shocks must be installed with the cylinder body mounted at the axle. [Shaft UP, Body DOWN] BILSTEIN 5100 SERIES can be mounted Shaft Up or Shaft Down.

Install the SUPERLIFT shock decals.

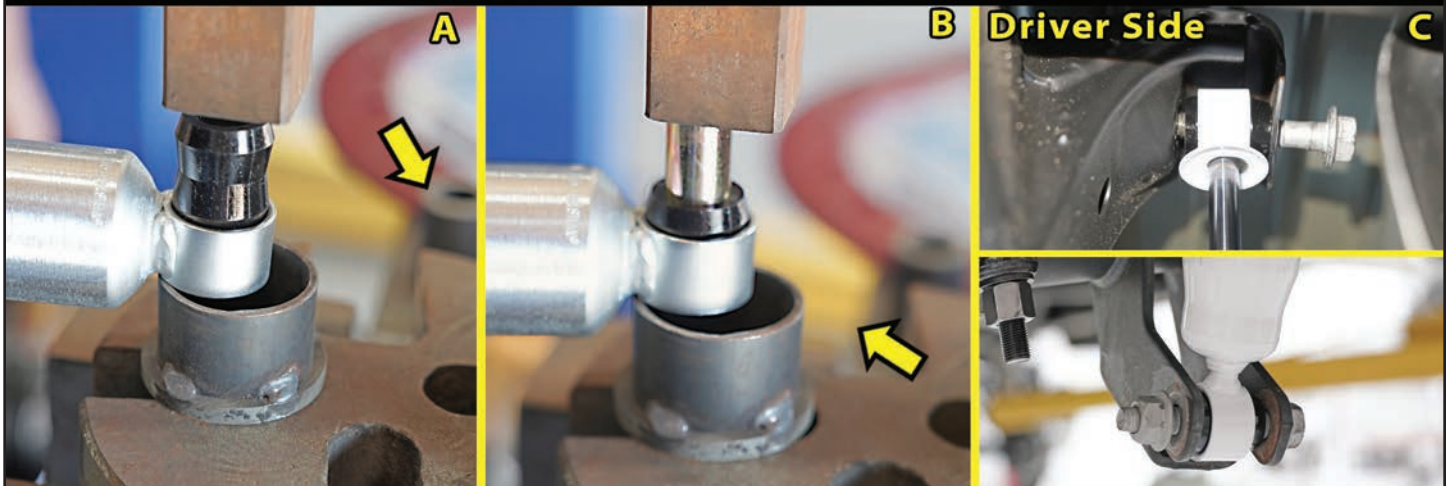
[Illustration 44**Install SUPERLIFT or BILSTEIN Rear Shocks...****45. TIRES / WHEELS...**

[Illustration 35] Reinstall tires and wheels. Tighten the lug nuts in the sequence shown. (151) [21mm]

⚠ WARNING: When the tires / wheels are installed, always check for and remove any corrosion, dirt, or foreign material on the wheel mounting surface, or anything that contacts the wheel mounting surface (hub, rotor, etc.). Installing wheels without the proper metal-to-metal contact at the wheel mounting surfaces can cause the lug nuts to loosen and the wheel to come off while the vehicle is in motion.

⚠ WARNING: Retighten lug nuts at 500 miles after any wheel change, or anytime the lug nuts are loosened. Failure to do so could cause wheels to come off while vehicle is in motion.

Lower vehicle to the floor.

46. CLEARANCE CHECK...

Check all hardware for proper torque specifications.

With the vehicle on the ground, check all components for proper operation and clearances. Pay special attention to the clearance between the tires / wheels, brake hoses, wiring, etc. Check tire/wheel clearance with the fenders/bumper as well as with the steering knuckle.

47. WHEEL ALIGNMENT...

Realign vehicle to factory OEM specifications. It is necessary to have a proper and professional wheel alignment performed by a certified alignment technician. Align the vehicle to factory specifications. It is recommended that your vehicle alignment be checked after any off-road driving.

48. HEADLIGHTS...

Re-adjust headlights to proper setting. In addition to your vehicle alignment, for your safety and others, it is necessary to check and adjust your vehicle head lamps for proper aim and alignment.

49. FOUR WHEEL DRIVE...

Activate four wheel drive system and check for proper engagement.

50. SUPERLIFT WARNING DECAL...

Install the **Warning to Driver** decal on the inside of the windshield or dash within the Driver's view.

[Illustration 35**Lug Nut Torque Sequence...**

Follow the Sequence Below to Torque the Lug Nuts

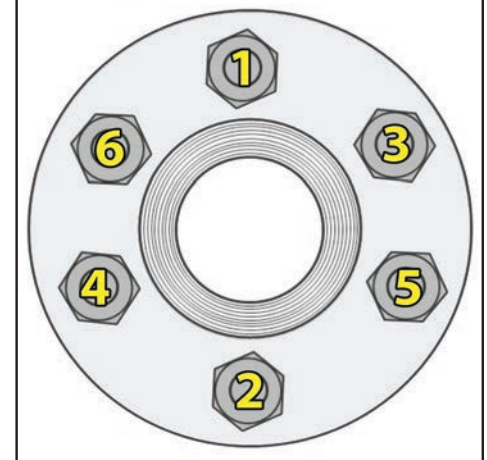

IMPORTANT MAINTENANCE INFORMATION

⚠️WARNING: It is the ultimate buyer's responsibility to have all bolts / nuts checked for tightness after the first 100 miles and then every 1000 miles. The steering, suspension and driveline systems, plus wheel alignment should be inspected by a qualified professional mechanic at least every 3000 miles.

LIMITED LIFETIME WARRANTY / WARNINGS

Your SUPERLIFT® product is covered by the Limited Warranty explained below that gives you specific legal rights. This limited warranty is the only warranty SUPERLIFT® makes in connection with your product purchase. SUPERLIFT® neither assumes nor authorizes any retailer or other person or entity to assume for it any other obligation or liability in connection with this product or limited warranty.

SUPERLIFT, LLC, LIMITED LIFETIME WARRANTY

What is covered? Subject to the terms below, SUPERLIFT® will repair or replace its products found defective in materials or workmanship for so long as the original purchaser owns the vehicle on which the product was originally installed. Your warranter is SUPERLIFT, LLC, doing business as SUPERLIFT® Suspension Systems ("SUPERLIFT®").

What is not covered? Your SUPERLIFT® Limited Warranty does not cover products SUPERLIFT® determines to have been damaged by or subjected to:

- Alteration, modification or failure to maintain.
- Normal wear and tear (bushings, rod ends, etc.). Scratches or defects in product finishes (powder coating, plating, etc.).
- Damage to, or resulting from, the vehicle's electronic stability system, related components or other vehicle systems.
- Racing or other vehicle competitions or contests. Accidents, impact by rocks, trees, obstacles or other aspects of the environment.
- Theft, vandalism or other intentional damage.

Remedy Limited to Repair or Replacement. The exclusive remedy provided hereunder shall, upon SUPERLIFT's inspection and at SUPERLIFT's option, be either repair or replacement of the product covered under this Limited Warranty. Customers requesting warranty consideration should contact SUPERLIFT® by phone (1-800-551-4955) to obtain a Returned Goods Authorization number. All removal, shipping and installation costs are customer's responsibility.

If a replacement part is needed before the SUPERLIFT® part in question can be returned, you must first purchase the replacement part. Then, if the part in question is deemed warrant-able, you will be credited / refunded.

OTHER LIMITATIONS - EXCLUSION OF DAMAGES - YOUR RIGHTS UNDER STATE LAW

- Neither SUPERLIFT® nor your independent SUPERLIFT® dealer are responsible for any time loss, rental costs, or for any incidental, consequential or other damages you may have.
- This Limited Warranty gives you specific rights, and this is the only warranty SUPERLIFT® makes in connection with your product purchase. You may also have other rights that vary from state to state. For example, while all implied warranties are disclaimed herein, any implied warranty required by law is limited to the terms of our Limited Lifetime Warranty as described above. Some states do not allow limitations of how long an implied warranty lasts and / or do not allow the exclusion or limitation of incidental or consequential damages, so the limitations and exclusions herein may not apply to you. SUPERLIFT® neither assumes nor authorizes any retailer or other person or entity to assume for it any other obligation or liability in connection with this product or Limited Warranty.

IMPORTANT PRODUCT USE AND SAFETY INFORMATION / WARNINGS

⚠️WARNING: As a general rule, the taller a vehicle is, the easier it will roll over. Offset, as much as possible, what is lost in rollover resistance by increasing tire track width. In other words, go “wide” as you go “tall”; always use as wide a tire and wheel combination as feasible to enhance vehicle stability. We strongly recommend, because of rollover possibility, that the vehicle be equipped with a functional roll bar and cage system. Seat belts and shoulder harnesses should be worn at all times. Avoid situations where a side rollover may occur.

Generally, braking performance and capabilities are decreased when significantly larger / heavier tires and wheels are used. Take this into consideration while driving. Also, changing axle gear ratios or using tires that are taller or shorter than factory height will cause an erroneous speedometer reading. On vehicles equipped with an electronic speedometer, the speed signal impacts other important functions as well. Speedometer recalibration for both mechanical and electronic types is highly recommended.

Do not add, alter, or fabricate any factory or aftermarket parts to increase vehicle height over the intended height of the SUPERLIFT® product purchased. Mixing component brands is not recommended.

WE WANT TO SEE YOUR RIDE...

Grab photos of your SUPERLIFT Equipped truck in various poses and in action.

Email pictures to us at sales@superlift.com

Tag us on **Facebook:** [@superlift suspension systems](https://www.facebook.com/superlift.suspension)

Tag us on **Instagram:** [#superlift](https://www.instagram.com/superlift), [#superliftsuspension](https://www.instagram.com/superliftsuspension), [#superliftequipped](https://www.instagram.com/superliftequipped)

THANKS For Choosing SUPERLIFT...

For questions, technical support and warranty issues relating to this SUPERLIFT products, please contact SUPERLIFT directly.

SUPERLIFT SUSPENSION
300 Huey Lenard Loop Rd.
West Monroe, Louisiana 71292
Phone: (318) 397-3000
Sales / Tech: (800) 551-4955
Fax: (318) 397-3040
SUPERLIFT.COM